

INSTALLATION INSTRUCTION MANUAL PHASE FAILURE RELAY / SPP WITH WATER LEVEL GUARD / PHASE SEQUENCE RELAY

VSP D1



VSP D2



VPG D1



USP D1



S1 VMR7



These relay's are phase failure relay & offers protection against

- * Unbalanced voltage condition.
- * Phase failure condition.
- * Phase sequence reversal condition.
- * Dry running condition for pumps.

MOUNTING :

These relay's can be Rail Mounted or Panel Mounted. It is suitable for 35mm RAIL .

TRIP SETTING, TRIP DELAY AND RESETTING :

These refer following table of respective relay.

TECHNICAL SPECIFICATIONS OF	VSP D1	VSP D2	VPG D1	USP D1	S1 VMR7
1. SYSTEM SUPPLY VOLTAGE :	110/220/230/240/380/415/440 VAC ± 20%	110 / 220 / 230 / 240 / 380 / 415 VAC ± 20%	415 VAC, 3Ø ± 20 %	415 VAC ± 20 %	380-440 VAC ± 20 % 3phase-3 wire
2. AUX. SUPPLY :	110/220/230/240/380/415/440 VAC ± 20%	110 / 220 / 230 / 240 / 380 / 415 VAC ± 20%	NA	IN BUILT	In - Built from three phase
3. FREQUENCY :	50 / (60) Hz, ± 3%	50 / (60) Hz, ± 3%	50 Hz ± 3%	50 Hz, ± 3%	48 to 63 Hz.
4. POWER CONSUMPTION :	3 VA (max.)	3 VA (max.)	3 VA Max.	3 VA (max.)	3 VA (max.)
5. OUTPUT RELAY CONTACT :	1 Changeover	2 Changeover	1 Changeover	1 Changeover	1CO.
6. OUTPUT CONTACT RATING (RESISTIVE):	5Amp., 240 VAC	5Amp., 240 VAC	5 A, 240 VAC (Resistive)	5Amp., 240 VAC	5 Amp, 240VAC [resistive]
7. LIFE EXPECTANCY :	0.5 x 10 ⁶ operations at 100% rating	0.5 x 10 ⁶ operations at 100% rating	0.5 x 10 ⁶ Operations At 100% Rating	0.5 x 10 ⁶ operations at 100% rating	0.5 x 10 ⁶ operations at 100% rating
8. UNBALANCE TRIP SETTING :	40V ± 6V	30 to 70V ± 6V	40V ± 6V (Fixed) Dry Running: As Per Sensor Prod Positioning	60V ± 6V	NA
9. SET ACCURACY :	NA	± 10% of set value	NA	NA	NA
10. TRIP TIME DELAY :	3.5 Sec. ± 1.5 Sec.	3.5 Sec. ± 1.5 Sec.	2 to 5 seconds	3.5 Sec. ± 1.5 Sec.	Instant
11. TEST PUSH BUTTON DELAY :	NA	3.5 Sec. ± 1.5 Sec	NA	NA	NA
12. RESETTING :	Auto Reset	Auto, Manual, Remote Reset	Auto Reset	Auto Reset	Auto reset
13. RESET GAP :	10 - 18V	10 - 18V	10 - 18 V	10 - 18V	NA
14. INDICATION :	L1 : Green - Power ON L2 : Red - Trip	L1 : Green - Power ON L2 : Red - Trip	NA	L1 : Green - Power ON L2 : Red - Trip	L1 : Green - Power ON L2 : Red - RLY (Steady ON for RP)
15. ENCLOSURE :	ABS.	ABS.	ABS	ABS.	S1 SERIES-ABS-PC-ABS
16. DIMENSIONS [mm] :	Overall : 76 X 30.5 X 117.5 Mounting : 68 center to center	Overall : 76 x 56.5 x 117.5 Mounting : 68 x 27	76 x 30.5 x 117.5 68 [Center To Center]	Overall : 76 X 30.5 X 117.5 Mounting : 68 center to center	OVERALL = 96 X 17.5 X 60 MOUNTING = Rail Mounting
17. MOUNTING :	35 mm Rail Mounting & Panel Mounting	35 mm Rail Mounting & Panel Mounting	Panel Mounting And 35 mm Rail Mounting	35 mm Rail Mounting & Panel Mounting	35 mm Rail Mounting & Panel Mounting
18. WEIGHT [gms] :	320 (approx.)	400 (approx.)	300	320 (approx.)	70
19. OPERATING CONDITIONS :	TEMPERATURE : -5°C to +60°C HUMIDITY : Upto 95% Rh	TEMPERATURE : -5°C to +60°C HUMIDITY : Upto 95% R.H.	-5°C to 60° C Upto 95 % R.H.	TEMPERATURE : -5°C to +60°C HUMIDITY : Upto 95% Rh	TEMPERATURE = -5°C to +60°C HUMIDITY = Upto 95% RH
20. Level Sensor : Weight	NA	NA	1 No. Stainless Steel Prod Approx. Weight: 15gms	NA	NA
21. Liquid Resistance :	NA	NA	150 K. Ohms	NA	NA
22. Environment					Pollution Degree 2

COMPLIANCE TO STANDARDS

TEST	IEC STD.	TEST	IEC STD.
1. EFT Test of Auxiliary Supply	61000-4-4	7. H.V. Test (Dielectric Test)	60255-5
2. EFT Test of System Supply	61000-4-4	H.V. Test (Dielectric Test)	60255-5
3. Surge Test of Auxiliary Supply	61000-4-5	8. Insulation Resistance Test	60255-5
4. Surge Test of System Supply	61000-4-4	9. Dry Heat Test	60068-2-2
5. *Voltage Interruption, Variation & Dip Test	61000-4-11	10. Damp Heat test (Steady State)	60068-2-30
6. ESD Test (Contact Discharge)	61000-4-2	11. Damp Heat test (cyclic test)	60068-2-78
ESD Teast (Air Discharge)	61000-4-2		

Note: * applicable foe VSP D1 & VSP D2

WARRANTY - AGAINST ALL MANUFACTURING DEFECTS FOR 18 MONTHS FROM DATE OF SUPPLY OR 12 MONTHS FROM INSTALLATION WHICHEVER IS EARLIER

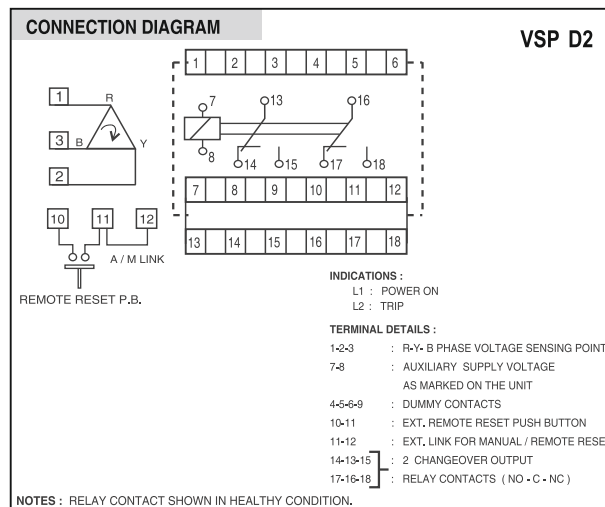
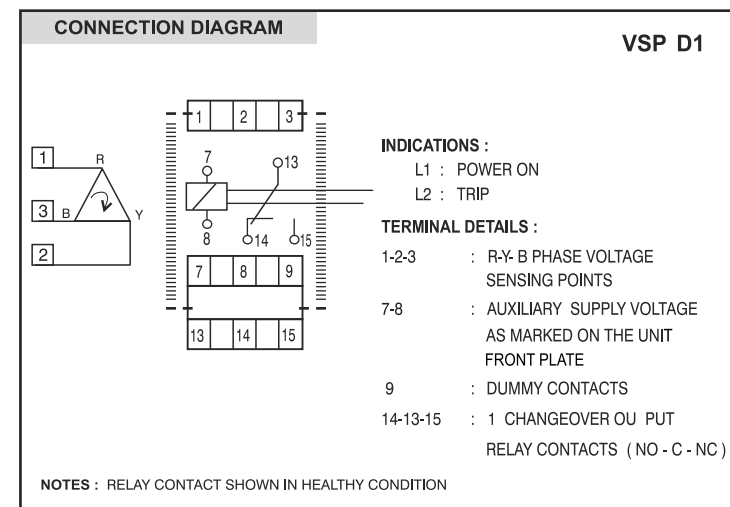
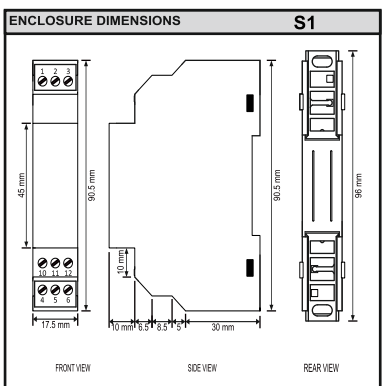
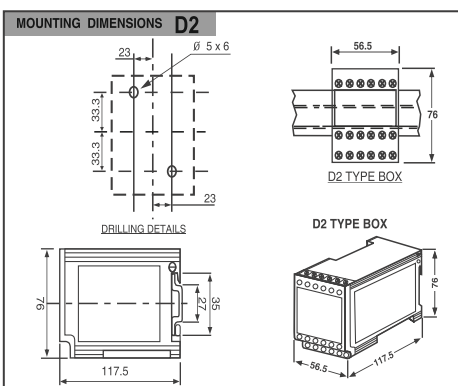
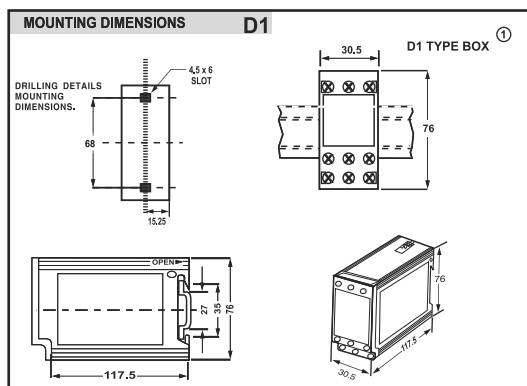
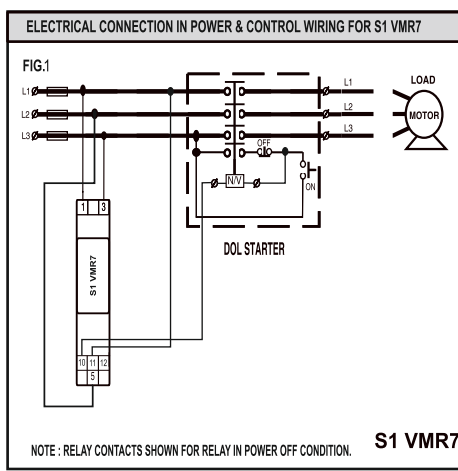
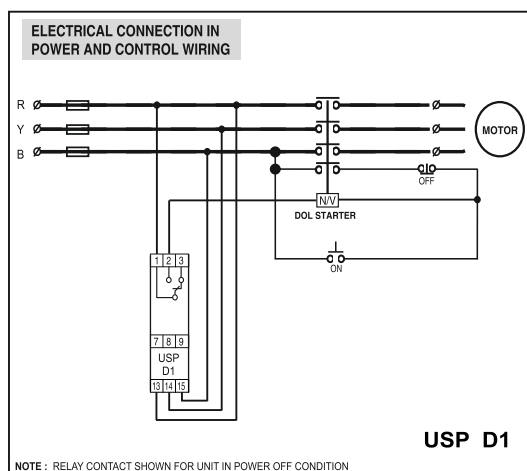
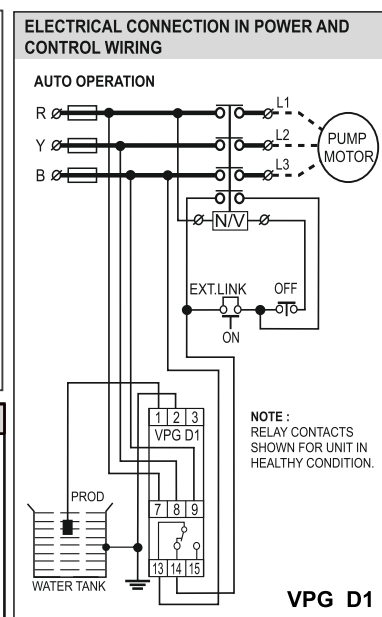
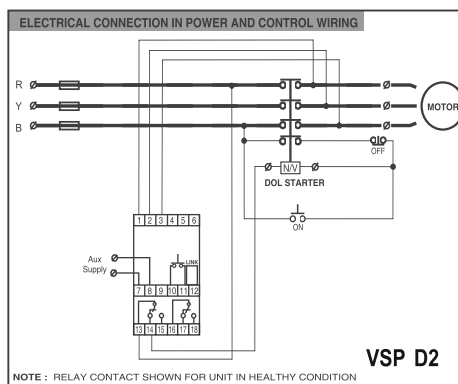
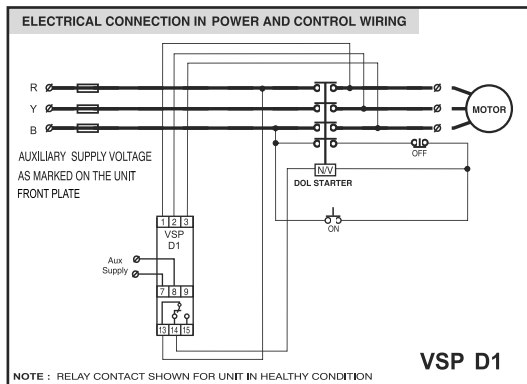

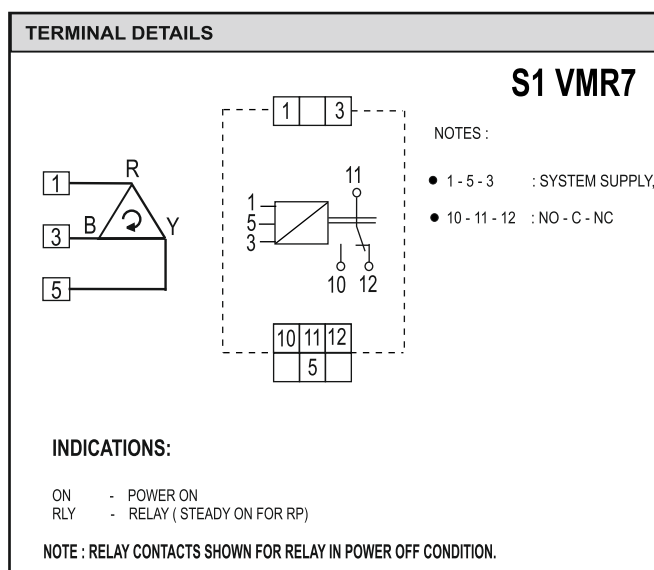
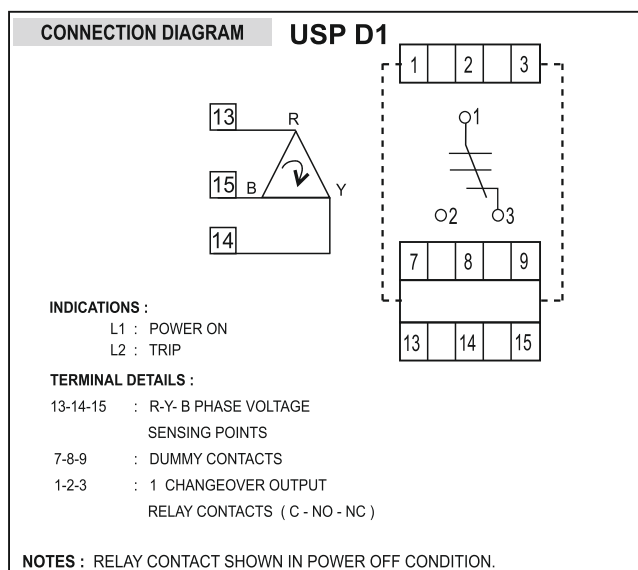
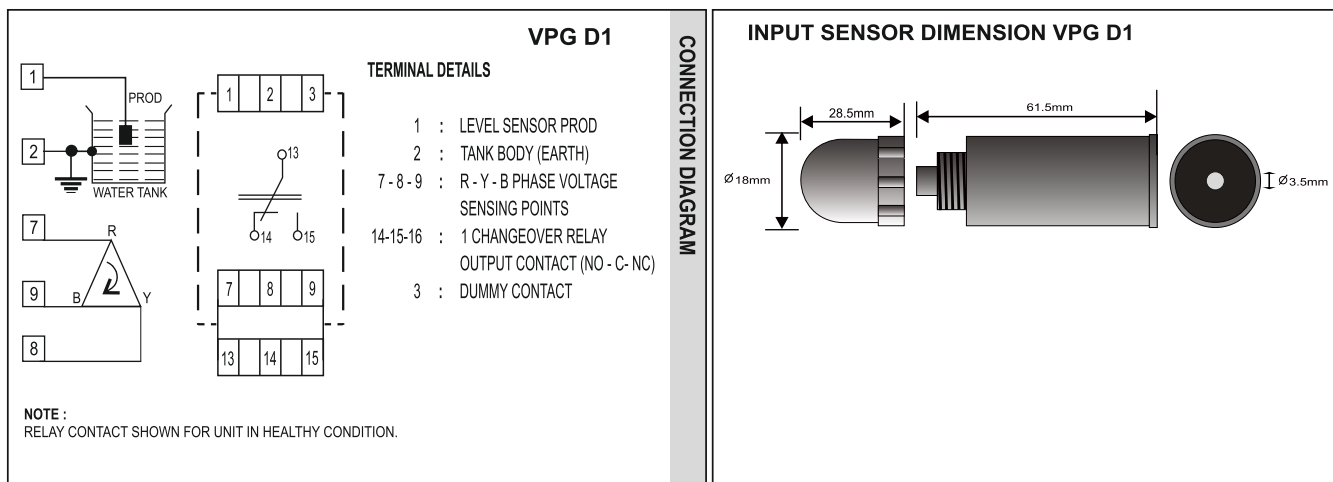

Instructions for Screw Gun torque adjustment -

- Torque should be 1 Nm max.
- Max 2.5 sq. mm size wire can be used.

WEEE (Waste Electrical & Electronic Equipment)
Regulations: After end of equipment life, recycle or disposal needs to be done as per guidelines or handover it to Ewaste processing authorized agencies. For more details contact us.

WARRANTY - AGAINST ALL MANUFACTURING DEFECTS FOR 18 MONTHS FROM DATE OF SUPPLY OR 12 MONTHS FROM INSTALLATION WHICHEVER IS EARLIER

www.minilecgroup.com

Minilec (India) Pvt. Ltd.

Factory & Head Office: S. No. 1073/1-2-3, At Post: Pirangoot, Pune 412 111, India