

USER'S MANUAL

MBAS 11

ver. 01 (03/03/2013)

MICROPROCESSOR BASED ALARM ANNUNCIATOR SYSTEM

1.00 Scope

The scope of this USER'S MANUAL is limited to the product named MBAS11 annunciation system / model manufactured, marketed & serviced by MINILEC. The scope is further limited to the extent of technical specifications enlisted in the USER'S MANUAL only.

Users should not refer this manual for using any other annunciator other than MBAS 11 with unspecified technical specifications & features.

2.00 MBAS 11 System Details

2.01 General

The MBAS 11 model is microprocessor based alarm annunciator system.

MINILEC, a well known name in the field of electronic motor protection and microprocessor based annunciators, offer this unique alarm annunciator system based on latest single chip microcontroller technology with totally new face—lift and with considerable size reduction, having moulded enclosure, with 92mm X 92mm panel cutout.

These highly reliable and compact system offer fixed operating sequence. Minilec offers annunciators for all applications.

2.02 Standard Features

The Design Features

- Single chip microcontroller logic.
- Opto Isolated Inputs & Outputs.
- Super Bright LED for fault identification.
- High Noise immunity / isolation.
- Switch mode power supply.
- Self surveillance watchdog LED.

The Constructional Flexibility

- With panel cutout size 92mm X 92mm.
- Moulded enclosure.

The Functional Features

- Manual Reset (S1) with Lamp Test having fixed grouping **OR** Auto Reset (S2) with Lamp Test having fixed grouping
- Potential Contact Inputs (with -Ve common).
- Relay output for external Audible Hooter.

2.03 Optional Features

- Programmed custom built operating sequence.
- External NO type Push Buttons.

2.04 Constructional Details

• The CPU Block

The Central Processing Unit block scans and processes optically isolated potential inputs and trigger the corresponding LED and hooter relay as per the operating sequence given in Operating Sequence chart.

The CPU block's 'BRAIN' is the single chip microcontroller IC which is powered by regulated +5Vdc from Power Supply block.

• The Power Supply Block

The Power Supply block is integral. This switch mode power supply accepts specified AC or DC input supply 90 – 270 Vac / dc and convert it into three different filtered noise free DC outputs which are fed to the CPU block (+5Vdc & +12Vdc isolated) and to the facia block (+12Vdc).

• The Facia Block

Facia block contains Front Acrylic plate. Single super bright LED is used for fault identification & the fault description is given alongside the LED. These LEDs are visible from the front. Facia block is also incorporated with 3 nos. / 4 nos. black colour protruding (Tact) keys.

2.05 Standard Operating Sequence

The MBAS 11 annunciation system is programmed to operate as per following operating sequences.

SEQUENCE : Manual-Reset Sequence (S1) with Lamp Test having Fixed Group Relay Alarm Feature

Sr. No.	Conditions	Visual Window Display	Relay 1 (for Hooter) (Note 1)	Relay 2 (for Group Faults) (Note 2)
1	Normal Condition (No Fault)	OFF	OFF	OFF
2	Fault Abnormal	Fast Flashing	ON	ON
3	Accept while Abnormal / Normal	Steady ON	OFF	ON
4	Reset while Normal	OFF	OFF	OFF
5	Normal Condition (No Fault)	OFF	OFF	OFF
6	Fault Abnormal	Fast Flashing	ON	ON
7	Accept while Abnormal / Normal	Steady ON	OFF	ON
8	Reset while Abnormal	Steady ON	OFF	ON
9	Reset while Normal	OFF	OFF	OFF
10	Test Key Kept Pressed	Steady ON	OFF	OFF
11	Test Key Release	OFF	OFF	OFF

NOTES:

- Note 1:** Corresponding to Relay 1 ON/OFF Condition, the I1 - C1 contacts are close/open respectively.
- Note 2:** Corresponding to Relay 2 ON/OFF condition, the I2 - C2 contacts are close/open respectively. Once Relay 2 contact gets ON, it will remain ON till any of visual window display is fast flashing or steady ON.
- Note 3:** Test Push Button Operation – For Lamp Test Only.
- Note 4:** Mute Push Button Operation - Relay 1 gets OFF when Mute Key is pressed.

SEQUENCE : Auto-Reset Sequence (S2) with Lamp Test having Fixed Group Relay Alarm Feature

Sr. No.	Conditions	Visual Window Display	Relay 1 (for Hooter) (Note 1)	Relay 2 (for Group Faults) (Note 2)
1	Normal Condition (No Fault)	OFF	OFF	OFF
2	Fault Abnormal	Fast Flashing	ON	ON
3	Accept while Abnormal	Steady ON	OFF	ON
4	Fault Return to Normal	OFF	OFF	OFF
5	Normal Condition (No Fault)	OFF	OFF	OFF
6	Fault Abnormal	Fast Flashing	ON	ON
7	Accept while Normal	OFF	OFF	OFF
8	Test Key Kept Pressed	Steady ON	OFF	OFF
9	Test Key Release	OFF	OFF	OFF

NOTES:

- Note1:** Corresponding to Relay 1 ON/OFF Condition, the I1 - C1 contacts are close/open respectively.
- Note 2:** Corresponding to Relay 2 ON/OFF condition, the I2 - C2 contacts are close/open respectively. Once Relay 2 contact gets ON, it will remain ON till any of visual window display is fast flashing or steady ON.
- Note 3:** Test Push Button Operation – For Lamp Test Only.
- Note 4:** Mute Push Button Operation - Relay 1 gets OFF when Mute Key is pressed.

2.06 System Enclosure

The MBAS 11 annunciation system is configured in 96 mm X 96 mm type white moulded enclosure.



Fig 1 Standard Enclosure

The size conforms to standard bezzel (96mm X 96mm)

and panel cutout (92mm X 92mm).
The terminal block is located at the rear of MBAS 11.

2.07 Scope of Supply

Minilec offers to supply its Microcontroller Based Alarm Annunciation System MBAS 11 as an isolated system to be installed in a suitable control cubicle.

Minilec's scope of supply is limited to following :

1. MBAS 11 standard annunciator model.
2. External NO type Push Buttons.

Following mandatory accessories are also supplied with MBAS 11 :

1. Noise Suppressing Network (RRC N/W) supplied with the annunciators to be wired across the inductive load of the audible device.
2. Mounting clamps (quantity – 2) for panel flush mounting.
3. User's manual (may be supplied with consignment or will be sent to the user / buyer separately.)

2.08 Optional Accessories

Following optional accessories will be supplied only if these are ordered by buyer as additional facilities :

1. Industrial diaphragm type AC or DC Powered Hooter (Audible Device).
2. Electronic (Tone Controlled) type AC or DC Powered Hooter (Audible Device).
3. External NO type Push Buttons.

2.09 List of Spares (Recommended)

1. Pre-programmed Microcontroller Chip.
2. Front Acrylic with Legends.

2.10 Technical Specifications

1. Supply Voltage 90 – 270Vac / dc
2. Supply Frequency 50 / 60 Hz ± 3 % (For AC)
3. Windows 16 Fixed
4. Display (window) Single LED Type (3mm LED, 1 No. each) with replaceable Legend
5. Legend Window Dimensions 06mm X 26mm (H X L)
6. Unit Dimensions Overall (L x W x D) Cutout (L x W)
96x96x108 mm 92x92 mm +1/-0mm
7. Weight 550gm.
8. Power Consumption 1.5 Watt / window.
9. Flash Rate 50 - 60 Flash / min. in fast flash.
10. Legends Pre-printed Positive on Paper
11. Operating Sequence
 1. Manual Reset (S1) with Lamp Test having group relay (fixed) alarm feature. Grouping is Fixed. Fixed NO type (Factory Set).
 - OR**
 2. Auto Reset (S2) with Lamp Test having group relay (fixed) alarm feature. Grouping is Fixed. Fixed NO type (Factory Set).

12. Input Signal (For Faults)	110Vdc / 220Vdc ± 20 % (with -Ve common)
13. Input Interrogation Voltage(For Keys)	+ 12 Vdc
14. LED colour for Window	Red only
15. Output Contacts	Two opto isolated Electromagnetic Relay. 1 NO (For Hooter) and 1 NO (For Group Faults)
16. Output Contact Rating	5Amp, 240Vac (Resistive) .
17. Operational Temperature	0°C to + 60°C
18. Storage Temperature	- 10 °C to + 70°C
19. Humidity	Upto 95% Rh
20. Inbuilt Push Buttons	1. Four Nos. (Test, Mute, Accept, Reset) at front, when Manual Reset (S1) with Lamp Test having group relay (fixed) alarm feature. OR 2. Three Nos. (Test, Mute, Accept) at front, when Auto Reset (S2) with Lamp Test having group relay (fixed) alarm feature.
21. Enclosure	ABS type moulded enclosure.

3.00 Installation Instructions Pre-Installation Check

3.01 Pre-Installation Check

1. Check the packing and unit of MBAS 11 for any physical damage.
2. Check the unit for legends, Fault Input Voltage, Power Supply Voltage marked on the unit with purchase order details. Also check the accessories like RRC network, two mounting clamps with mounting studs, Installation Instruction and other optional accessories if ordered like hooter, external push button etc.
3. Connect the power supply as mentioned on the unit (Refer fig 3 External Terminal Connection Diagram for Annunciator) and wait. The 'Self Surveillance' watch-dog LED will switch 'ON' and start flashing. This indicates your MBAS 11 logic circuit is operating perfectly as designed.
4. Press & hold 'TEST' button, then all window LEDs will steady ON. After releasing the 'TEST' button all window LEDs will gets OFF.
5. Connect all fault potential inputs and relay outputs as per fig 3 External Terminal Connection Diagram for Annunciator.
6. Connect RRC Networks across Hooter Coils as shown in fig 4 Common Hooter Relay connection diagram. This RRC Networks are supplied assuming that, supply voltage of annunciator and hooter is same. If hooter is of different supply voltage then do not connect given RRC Networks and please ask for RRC Networks suitable for hooter coil supply voltage.
7. Now check the unit as per given operating sequence details chart given in clause 2.05 of chapter 2.00 by giving Potential Input (with -Ve common) to faults.
8. All the above test will ensure that your MBAS 11 annunciators are delivered perfectly as per ordered specifications.

3.02 Installation

Install the MBAS 11 annunciator modules in designed panel cutout, inserting from front of panel. Before installation please ensure that in the vicinity of MBAS 11 there are no equipments / systems generating heat, vibration, noise, RF signals etc.

3.03 Mounting

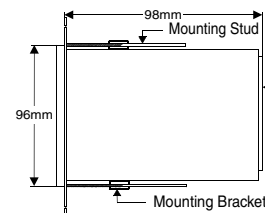

For fixing the unit use the mounting brackets supplied with the annunciator. Tight Mounting Stud suitably so that the unit does not move or get loose.

Fig 2 Front Panel Mounting

3.04 External Electrical cable Connections

(Refer fig 3 External Terminal Connection diagram for Annunciator)

Connect various fault contact cables (2.5 sq. mm max.) with pin lugs to the fault inputs at terminals with respective labels. Please ensure that these are potential input (110Vdc / 220Vdc) contacts which carry voltage from source end (**CAUTION: The Fault Potential Input is High DC Voltage. So take care during Connection & testing the Unit.**) Connect Hooter(s) along with RRC Network.

3.05 Post Installation Checks

Before connecting power supply, please check all wiring terminals for correctness. Please ensure power supply voltage is same as that of mentioned on MBAS 11 Unit. **The Fault Potential Input is High DC Voltage. So be cautious.**

3.06 Precautions

Please ensure that power supply to MBAS 11 Unit is stable & free from spikes & surges. Please ensure that fault contact cabling is away from power cabling & does not pick up RF signals. Please ensure that there is not heat generating & vibration near to the MBAS 11 installation.

4.00 Drawings / illustrations

4.01 Dimensional & Panel Cutout Details

1) Dimensions & panel cutout of Model

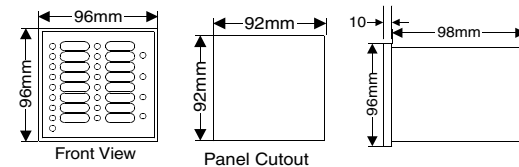

4.02 Legends Letter Size

Legend incorporates with pre-printed positive type legends only which gives the correct & clear information of fault. The space given for legends per fault description is 06mm X 26mm (Height X Length).

4.03 Window Numbering System

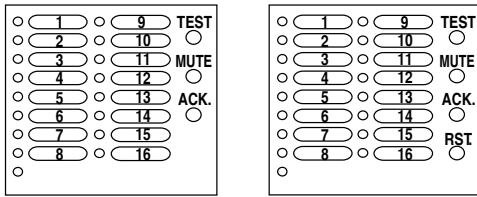

MBAS 11 (WITHOUT RESET KEY) MBAS 11 (WITH RESET KEY)

Window numbering system is shown for 16 point models for reference.

5.00 Connection Diagram

5.01 Fault Input Connection Diagram of Annunciator

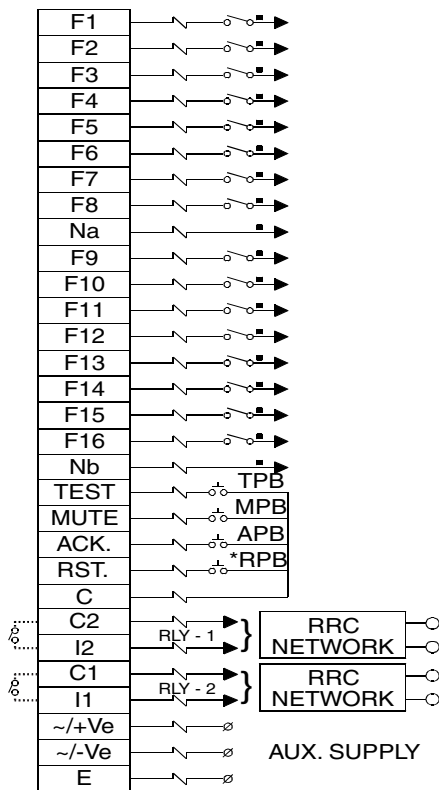
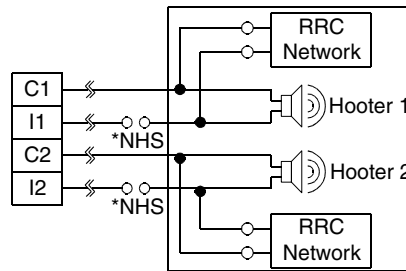

Fig 3 External Terminal Connection Diagram for Annunciator

NOTES :-

- 1) ■ - External Potential Fault Contacts.
- 2) F – Fault Input Contact.
- 3) Na – Common Point for Fault F1 to F8 (-Ve).
- 4) Nb – Common Point for Fault F9 to F16 (-Ve).
- 5) C – Common Point for Push Button Contact.
- 6) TPB – Test Push Button.
- 7) MPB – Mute Push Button.
- 8) APB – Acknowledge Push Button.
- 9) * RPB – Reset Push Button (Optional).
- 10) RLY - 1 – Normal Hooter Contact.
- 11) RLY - 2 – Group Fault Hooter Contact.
- 12) Internal connections are shown by dotted lines.
- 13) Connect RRC Network across hooter coil.

5.02 Hooter Relay Contact Connection, with RRC Network.



* NHS = Normal Hooter Supply

Fig 4 Common Hooter Relay Connection Diagram.

- Hooter 1 & Hooter 2 shown inside the box are external to the annunciator module.
- RLY1 & RLY 2 are universally provided with every MBAS 11, Fault Potential Input module.
- RRC Network assembly is supplied with every annunciator module. It is designed for normal power supply voltage of Hooter coil (load).
- RRC Network used for noise suppression.

Presumptions

- Normal supply voltage of MBAS 11 & Hooter coil supply voltage are same.
- RRC Network is mandatory across the Hooter coil.

WARRANTY

AGAINST ALL MANUFACTURING DEFECTS FOR 18 MONTHS FROM DATE OF SUPPLY OR 12 MONTHS FROM INSTALLATION WHICHEVER IS EARLIER.