

TECHNICAL LITERATURE & INSTALLATION INSTRUCTION

# D3 MPR1

MICROCONTROLLER BASED  
MOTOR PROTECTION RELAY



*minilec*<sup>®</sup>

S.NO.1073/1-2-3, A/P: PIRANGOOT  
PIN:412111,TAL:MULSHI,DIST: PUNE ( INDIA )  
TEL:(020)22922162 / 22922354 -57  
FAX:(020)22922134  
WEB SITE: [www.minilecgroup.com](http://www.minilecgroup.com)  
(version - 5,DT-07/03/18)

## 1. INTRODUCTION :

Thank you for selecting and purchasing minilec make D3 MPR1. It is micro-controller based motor protection relay. It uses state of the art digital technology to measure various parameter of the motor and take corresponding corrective actions. The system consists of hardware design to provide high degree of accuracy and reliability. The micro-controller based protection ensures high accuracy and disturbance free operation.

Packing of your D3 MPR1 will include following –

1. D3 MPR1 unit.
2. Installation manual.

## FUNCTIONS :

SR.NO.	PROTECTIONS	SR.NO.	FEATURES
1.	Over load	1.	Password Protection
2.	Current Unbalance	2.	Full load Current settable
3.	Current Single Phasing	3.	Ext. CT selectable
4.	Phase reverse	4.	IDMTL curve selection
5.	Lock Roter	5.	2 CO potential free contact outputs
6.	Under Current	6.	Protections with bypass facility (if not required)
7.	Over Current	7.	LED indication for power on & trip
8.	Earth Fault (Optional)	8.	Status mode showing load current
		9.	Parameter setting through LCD & key board
		10.	Operation on wide range auxiliary supply
		11.	Default factory setting or site selectable Parameter
		12.	Fault logging of last 10 faults
		13.	Start up delay settable

## ASSUMPTION TO BE CONSIDERED DURING SETTING PARAMETER OR DURING ANY WORKING CYCLE :

1. Default password is 0000. After installation of unit, change the password and keep it in safe hand. Master Password is 8679.
2. Auto exit option is enabled during setting mode, if user not presses any key up to 30 sec, then controller save current setting and exit from setting mode.
3. The factory setting is applicable for all parameter by assuming 100% rated current reference. For any other specification of motor, set corresponding CT ratio & full load current.
4. An IDMTL characteristic (as per selection) is always enabling during Motor ON.
5. All faults are to be resetted manually by pressing ▼ & ENTER key simultaneously.
6. Power ON indication is continuously ON when supply is present. It will be in flashing state if any protection is bypassed.
7. Test function is provided to check healthiness of unit. To enable test parameter press menu & ▲ key simultaneously for 4 sec. It is recommended to use this during motor off condition.

## 2. OPERATING MODES :

### STEPS TO ENTER IN SETTING MODE :-

1. After giving the power supply to the unit message on LCD display is:

MINILEC  
D3 MPR1

2. Second message on display (assume that system supply is absent and other healthy conditions) is 3-ph current in scrolling manner.

R-Ph / L1  
00.0

3. After the above messages press **MENU** key. You will get message

Set Mode  
PASSWORD

4. Press **ENTER** and you will get message on display \_

ENT PSW  
XXXX

5. Type the password using Up/Down keys (▲/▼). To shift to second digit press **ENTER** key. After entering correct password, you will go in setting mode.

Setting mode has following menu. You can see this mode on LCD display by pressing UP (▲) key. You can select particular mode and can set parameters as per requirements.

SET CURRENT	OVER LOAD	START UP DELAY	UNDER CURRENT
OVER CURRENT	UNBALANCE CURRENT	CURRENT SINGLE PHASING	REVERSE PHASING
LOCK ROTOR	EARTH FAULT	NEW PASSWORD	FACTORY SETTING

6. Select any one of the mode by pressing (▲/▼). For entering in particular menu press **ENTER** key. Details are given below.

## CURRENT PROTECTION :

### 1. SET CURRENT :

- a. Select the SET CURRENT option from setting parameter by using **ENTER** key.
- b. After pressing **ENTER** display will be

EXT CT  
XXX A

Set the primary current i.e. ext CT primary current by using ▲/▼ key. (If ext CT not used then keep display as 000 A). This setting is not available for model of rated current 20A or 50A.

- c. Then press **ENTER** key, you will get message

FLC  
XXX.XX

Set the full load current by using ▲/▼ & **ENTER** key.

- d. By pressing **ENTER** key you will come out of this mode and shows next setting mode.

## 2. OVER LOAD :

- a. Select over load parameter by pressing **ENTER** key.  
b. After pressing **ENTER** key display shows

OVER LOD  
BYP = NO

Press ▲/▼ keys to set YES / NO.

- c. After pressing **ENTER** key display shows

OVER LOD  
RST = MAN

Press ▲/▼ keys to select Auto / Manual reset.

- d. After pressing **ENTER** key display shows

IDMTL  
CHAR XX S

You can select IDMTL curve 2 / 5 / 10 / 20 / 30 sec as per requirement by using ▲/▼ keys. Press **ENTER** key to save selected curve.

## 3. START UP DELAY :

- a. After pressing **ENTER** key you will get message

Set Mode  
STRT DLY

- b. After pressing **ENTER** key you will get message

STRT DLY  
XXX Sec

- c. Set delay using ▲/▼ keys. Press **ENTER** key to save setting. You will enter in next mode.

Note: During start up delay, fault condition is ignored for set start up delay time. Hence one has to decide start up delay setting depending on the application. This delay not applicable for single phasing, reverse phasing fault, earth fault.

## 4. UNDER CURRENT :

- a. After pressing **ENTER** key you will get message

Set Mode  
UND CURT

- b. After pressing **ENTER** key you will get message

UND CURT  
BYP = NO

Use ▲/▼ keys to set YES / NO.

- c. After pressing **ENTER** key you will get message

UND CURT  
Trp = XXX %

Set trip setting using ▲/▼ keys & press **ENTER** key.

- d. Next message on display is

UND CURT  
RST = MAN

Set Auto / Manual reset type using ▲/▼ keys.

- e. Next message on display is

UND CURT  
Tdly = XX S

Set trip delay using ▲/▼ keys & press **ENTER** key.

## 5. OVER CURRENT :

Setting procedure is same as **UNDER CURRENT**.

**6. UNBALANCE CURRENT :**

This is percentage unbalance current calculated as per IEEE std.  
Setting procedure is same as **UNDER CURRENT** (Trip delay is fixed 04 sec).

$$\% UB = \frac{\text{Max. deviation with ref.to Average current value}}{\text{Average current value}} \times 100$$

**7. SINGLE PHASING :**

- a. Select the SINGLE PHASING Parameter from setting mode by using **ENTER** key. You will get message

Set Mode  
CURT SP

- b. After pressing **ENTER** key you will get message

CURT SP  
BYPASS = NO

Press **▲/▼** keys to select bypass YES / NO.

- c. After pressing **ENTER** key you will get message

CURT SP  
RST = MAN

Set Auto / Manual reset type using **▲/▼** keys.

- d. After pressing **ENTER** key you will get message

CURT SP  
Tdry = 04 sec

Parameter in this mode is fixed. Press **ENTER** key

**8. REVERSE PHASING :**

- a. Select the REVERSE PHASING Parameter from setting mode by using **ENTER** key. You will get message

Set Mode  
REV PHSE

- b. You need to retype password to enter in this mode.

ENT PSW  
XXXX

- c. After entering password, you can enable / disable Reverse Phase Protection feature by selecting YES or NO using **▲/▼** keys.

REV PHSE  
BYPASS = NO

- d. After pressing **ENTER** key, you will get message

REV PHSE  
RST = MAN

You can set Auto / Manual using **▲/▼** keys.

**9. LOCK ROTOR :**

- a. Select Lock Rotor parameter from setting mode using **ENTER** key. You will get message.

Set Mode  
LOCK RTR

- b. After pressing **ENTER** key you will get message.

LOCK RTR  
BYPASS = NO

You can set YES / NO using **▲/▼** keys.

- c. After pressing **ENTER** key you will get message.

LOCK RTR  
Trp = XXX %

Select the required % setting using **▲/▼** keys.

- d. After pressing **ENTER** key you will get message.

LOCK RTR  
RST = MAN

Set Auto / Manual using **▲/▼** keys.

- e. After pressing **ENTER** key you will get message

LOCK RTR  
Tdry = 01 Sec

Trip delay is fixed < 2 Sec for this fault. After pressing **ENTER** key you will enter in next mode.

**10. EARTH FAULT :**

- a. Select EARTH FAULT parameter from setting mode by using **ENTER** key. You will get message

Set Mode  
ERTH FLT

- b. After pressing **ENTER** key, you will get message

ERTH FLT  
BYPSS = NO

You can set YES / NO using ▲/▼ keys.

- c. After pressing **ENTER** key you will get message

ERTH FLT  
Trp = XXX%

Select the required % setting using ▲/▼ keys.

- d. After pressing **ENTER** key you will get message

ERTH FLT  
RST = MAN

Set Auto / Manual using ▲/▼ keys.

- e. After pressing **ENTER** key you will get message

ERTH FLT  
Td = XX.X S

Set trip delay using ▲/▼ keys.

- f. After pressing **ENTER** key you will get message

ERTH FLT  
CBCT=X A

Select CBCT 1A / 5A according to application. After pressing **ENTER** key you will enter in next mode.

**11. NEW PASSWORD SETTING OPTION :**

- a. Select this NEW PASSWORD Option from setting mode by using **ENTER** key.
- b. After pressing **ENTER**, you will get message on LCD

NEW PSW  
XXXX

You can set your new password using ▲/▼ keys. To shift to next digit press **ENTER** key.

- c. After setting new password press **ENTER** and you will get,

CNFM PSW  
XXXX

You can confirm your new password using ▲/▼ keys. To shift to next digit press **ENTER** key.

- d. After confirmation press **ENTER** key you will get,

Your PSW  
Changed

After this press **ENTER** key to save new password and to go in next mode.

**12. FACTORY SETTING :**

- a. Select FACTORY SETTING option from setting mode by using **ENTER** key. You will get message

Set Mode  
Fact Set

- b. After pressing **ENTER** key, display will show

Press  
ENT key

- c. To activate FACTORY SETTING, press **ENTER** key, (Still you want to continue with earlier setting wait 30 sec to auto exit) you will get message

Active in  
Nxt cycle

**STATUS MODE :-**

- a. To see the three-phase current, press ▲ key. You will enter in status mode and message on LCD,

Sts Mode  
MOTR PAR

- b. On pressing ▲ key you will see message

3 Ph Inst  
CURT VAL

- c. By pressing **ENTER** key, you will see message

R-ph / L1 XX.X
-------------------

Display will be scrolling for R-ph, Y-ph, B-ph and displaying instantaneous values of current.

- d. You can escape from this by pressing menu key or go in fault log mode by pressing **▲** key.

### **FAULT LOG :-**

By pressing **ENTER** key you can see logs of faults in LIFO manner. You can also see current values at the time of fault occurred by pressing **ENTER** key. Last 10 number of faults are stored which can be seen with the help of **▲ ▼ ENTER** keys.

You can escape from this by pressing menu key 2 times.

### **3. TROUBLE SHOOTING :**

1. P.ON indication not glowing.
  - a. Check auxiliary supply as mentioned on the unit.
  - b. Check all wiring and connections. There should not be any loose connection.
2. Trip LED indication glowing.
  - a. Current SP / UB fault.
    - I. Check for phase loss.
    - II. Check the current unbalance between the phases. Do the setting as per the unbalance or wait till it normalizes.
  - b. Phase Reverse fault.
    - I. Check for phase sequence if it is incorrect. Correct the same. Also check the current direction through unit. Current direction should be uniform.
  - c. Overload fault.
    - I. Check set current. It should be equal to nominal full load current of Motor.
    - II. If it is not as per FLC then correct the same through setting parameters.
    - III. Also check IDMTL curve selection.
  - d. Lock Rotor fault.
    - I. Check load current of motor & rotor movement.
    - II. Set start up delay properly.
  - e. Under current fault.
    - I. Check whether motor running on no load.
    - II. Check Under Current trip setting.
  - f. Over Current fault.
    - I. Check FLC setting & Over Current trip setting.
    - II. Set start up delay properly.
  - g. Earth fault.
    - I. Check CBCT current output. If get output after resetting then there must be current leakage in further connection. So repair this and test again.
    - II. Set trip setting & trip delay properly.
3. Apart from the above mentioned observations if any fault continue after suggested trouble shooting then contact Minilec.

### **ABBREVIATION USED :**

MOTR	- MOTOR	MOTR PAR	- MOTOR PARAMETERS
PSWD / PSW	- PASSWORD	Inst curt val	- INSTANTANEOUS CURRENT VALUE
CURT	- CURRENT	Flt Log	- FAULT LOG
FLC	- FULL LOAD CURRENT	CNFM PSW	- CONFIRM PASSWORD
IDMTL	- INVERSE TIME CHARACTERISTICS	Fact set	- FACTORY SETTING
UB CURT	- UNBALANCE CURRENT	ENT KEY	- ENTER KEY
Tdly	- TRIP DELAY	Nxt cycle	- NEXT CYCLE
CURT SP	- CURRENT SINGLE PHASING	Sts Mode	- STATUS MODE
REV PHSE	- REVERSE PHASING	BYPS	- BYPASS
ENT PSW	- ENTER PASSWORD	LOCK RTR	- LOCK ROTOR
STRT DLY	- START UP DELAY	NEW PSWD	- NEW PASSWORD
OVR CURT	- OVER CURRENT	UND CURT	- UNDER CURRENT
EF	- EARTH FAULT		

**EXTERNAL WIRING DIAGRAM :**

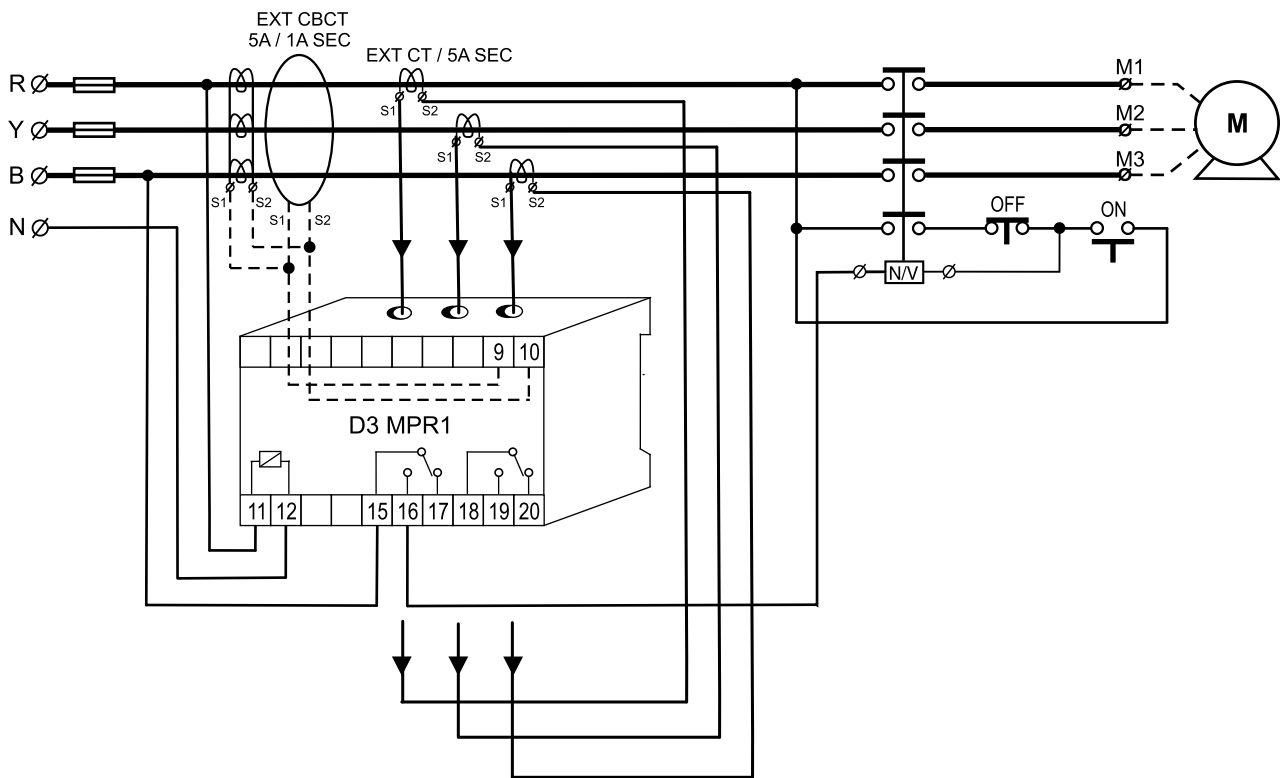

- NOTE:- 1) IF RATED CURRENT IS LESS THAN 5A THEN DO NOT USE EXTERNAL CT OF SECONDARY 5A.  
 2) RELAY CONTACTS SHOWN FOR UNIT IN POWER OFF / TRIP CONDITION.  
 3) EF PROTECTION IS AVAILABLE AS OPTIONAL, HENCE NEED TO SPECIFY WHILE ORDERING.  
 4) FOR 20A OR 50A RATED MODEL, EXTERNAL CT NOT APPLICABLE.

**STATUS MODE FLOWCHART :**

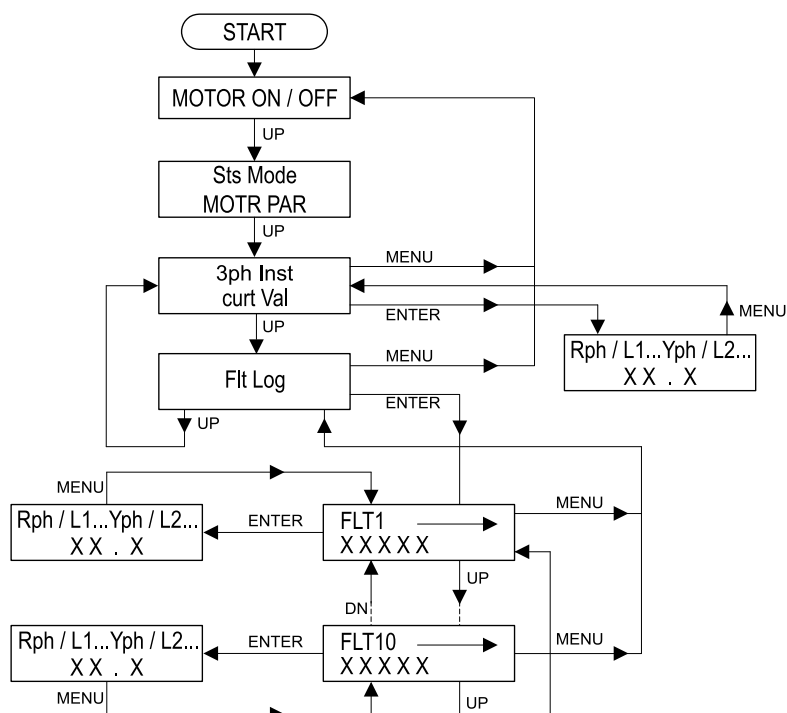

**PRODUCT SPECIFICATION :**

1. Aux Supply : 90 - 270VAC DC
2. Relay Output : 2 CO
3. Contact Rating : 5A @ 240VAC (Resistive)
4. Life Expectancy : 0.5 X 10<sup>6</sup> operations at 100% rating
5. Setting Parameters :

Sr. No.	Parameters	Range	Resolution	Fact Setting	Trip Delay Range	Fact Setting	Bypass Facility	Reset Type
1	* Ext. CT	50 - 600	5 Amp	100 Amp	NA	NA	NA	NA
2	Set current (FLC)	30 to 100% of FLA	1 Amp	20 / 50 / 100 Amp	NA	NA	NA	NA
3	Over Load	Above 115% of Set Value	NA	NA	IDMTL class 2, 5, 10, 15, 20, 30 sec	2 sec	Yes	Auto / Manual
4	Start up delay	0 - 60 sec	1 sec	10 sec	NA	NA	NA	NA
5	Under Current	30 - 90%	5%	50%	1 - 60 sec	5 sec	Yes	Auto / Manual
6	Over Current	110 - 350%	5%	200%	1 - 10 sec	2 sec	Yes	Auto / Manual
7	Current Unbalance	20 - 60%	5%	50%	4 sec Fixed (+/- 1 sec)	4 sec	Yes	Auto / Manual
8	Current Single Phasing	Yes	NA	NA	4 sec Fixed (+/- 1 sec)	4 sec	Yes	Auto / Manual
9	Reverse Phase	Yes	NA	NA	Instant (< 2 sec)	NA	Yes (Password Protected)	Auto / Manual
10	Rotor Lock	200 - 800%	50%	700%	Instant (< 2 sec)	NA	Yes	Auto / Manual
11	Earth Fault (Optional)	10 - 100%	10%	30%	0.5 - 10 sec	0.5 sec	Yes	Auto / Manual

6. Default Reset Type : Manual (By front ▼ + ENT keys)
7. Test Mode : Available (By front Menu + ▲ keys)
8. Display : 8 X 2 AN LCD
9. Display Parameters : Rotational display of each phase current ( R-L1 / Y-L2 / B-L3 )
10. Setting / Display Accuracy : +/- 5% (+/- 0.1 digit) at rated current
11. CT : Inbuilt through hole 5 Amp ( R / Y / B ) [ 20 Amp / 50 Amp Optional ]
12. Fault Log : For last 10 faults
13. Indications : Power On - Green  
Trip - Red
14. Enclosure : ABS (DIN Mounting)
15. Dimensions (mm) : 71 (H) X 100 (L) X 111 (D) (Overall)
16. Unit Weight : 400 gms (Approx)
17. Operating Conditions  
Temperature : -5° C to +60° C  
Humidity : Up to 85% Rh

**Note:-**

\* - External CT not applicable for 20A & 50A rated current model.



**SETTING MODE:**

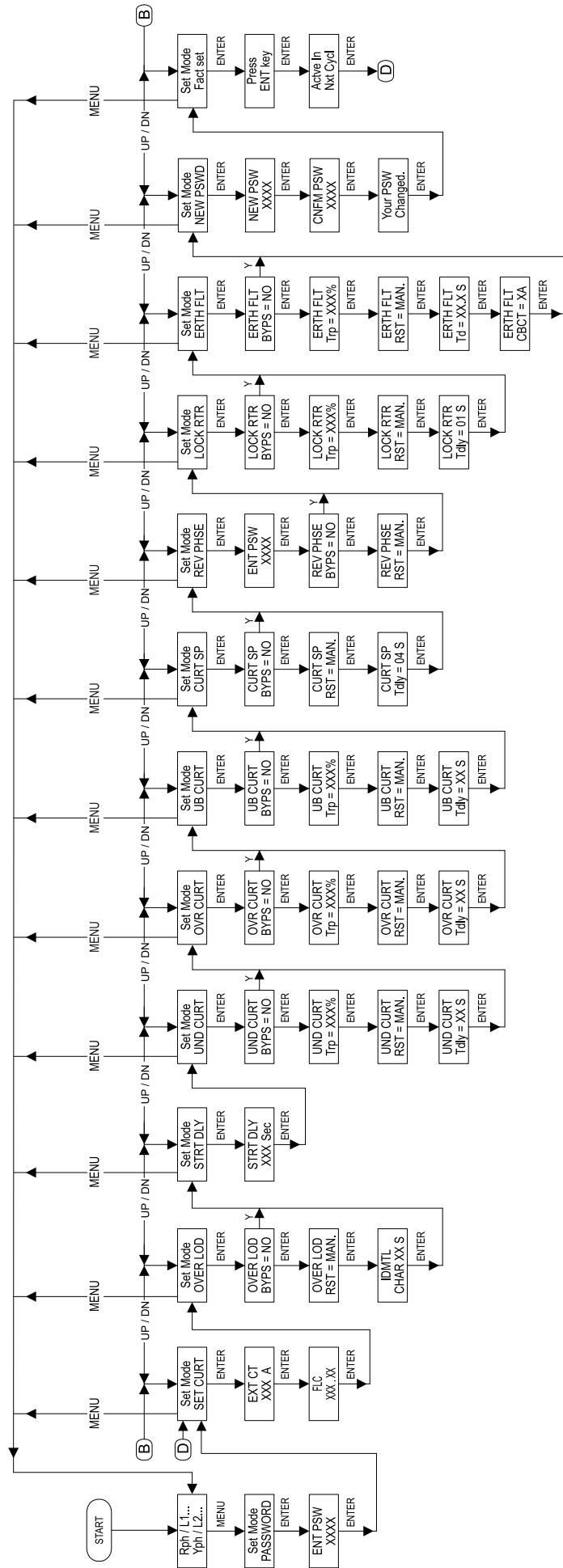

**OVERLOAD ( IDMTL ) CHARACTERISTICS:**

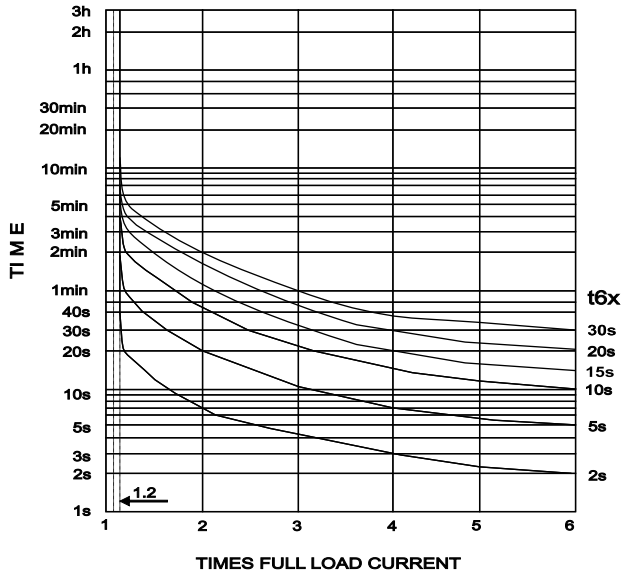

**DIN RAIL MOUNTING:**

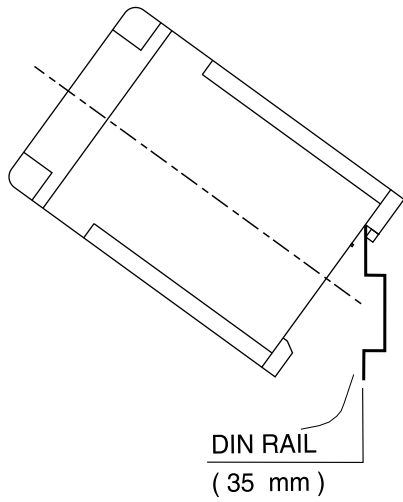

**OVERALL DIMENSION:**

