



# USER'S MANUAL MBAS 0600

ver 03 (21/11/2017)

## MICROPROCESSOR BASED ALARM ANNUNCIATOR SYSTEM

### 1.00 Scope

The scope of this USER'S MANUAL is limited to the product named MBAS 0600 annunciation systems / modules manufactured, marketed and serviced by MINILEC. The scope is further limited to the extent of technical specifications enlisted in this USER'S MANUAL only.

Users should not refer this manual for using any other annunciator other than MBAS 0600 with unspecified technical specifications and features.

### 2.00 MBAS 0600 System Details

#### 2.01 General

The MBAS 0600 series are microprocessor based annunciation systems.

MINILEC, a well known name in the field of electronic motor protection and microprocessor based annunciators, offer this unique alarm annunciation system based on latest single chip microcontroller or technology with a totally new face-lift and with considerable size reduction, having moulded enclosure, conforming to DIN panel cutouts.

These highly reliable and compact systems offer multipoint annunciation with operating sequence as per ISA standards and with optional features such as extra auxillary relay outputs, for remote annunciation, multicoloured front replaceable windows for easy differentiation of trip and non-trip or alarm and trip type of faults, manned/unmanned mode of operation etc.

Thus there is a readily available option for the specific needs of every installation. Minilec offers annunciators for all applications.

#### 2.02 Standard Features

##### The Design Features

- Single chip microcontroller logic.
- Opto isolated inputs and outputs.
- Super Bright LED window illumination.
- High Noise immunity / isolation.
- Switch mode power supply.
- Self surveillance watchdog LED.

##### The Constructional Flexibility

- Conforming to DIN panel cutouts.
- Replaceable snap-on window capsules.
- Replaceable window inscriptions (Legends).
- Two different window sizes.
- Expandable modules.
- Moulded enclosures.

#### The Functional Features

- Fixed Sequence (S1/S2/S3/S4).
- Sequence as per ISA standard.
- Potential free dry contact inputs.
- NO/NC inputs grouping selectable configuration.
- Relay output for external Audible Hooter.
- 3<sup>rd</sup> Relay optional for either of below mentioned feature.
  - a) Ring back hooter.
  - b) Supervisory control.

#### 2.03 Optional Features

- Site Selectable sequence (S1, S2, S3, S4).
- Preprogrammed Custom built operating sequence (without site selection facility).
- Trip & Non-Trip grouping facility for MBAS 0600 with Ring-Back Sequence only.
- Manned / Unmanned function .
- Fault Follower contact output per fault Input (NO) .
- 4 different colours for window illumination.
- Ringback sequence with optional 3<sup>rd</sup> relay output for Ringback hooter, with Trip & Non-Trip grouping facility.
- Supervisory control.
- Supply fail indication / annunciation.
- External and / or built-in control push buttons.
- In built Buzzer or Relay contact site selectable

#### 2.04 Constructional Details

##### ■ The CPU Block

The CPU block is integral mounted and accessible from side. This Central Processing Unit block scans and processes digital (dry contact) inputs and triggers the corresponding facia window and hooter relay and other optional auxillary relay output (if any), as per the operating sequence given in the order.

The CPU block's 'BRAIN' is the single chip microcontroller IC which is powered by +5 V DC regulated from Power Supply block.

##### ■ The Power Supply Block

The Power Supply block is also integral and accessible from side. This switch mode power supply accepts specified AC or DC input supply 24/48 V DC, 90-270 V AC / DC and converts it into 3 different filtered noise free DC outputs which are fed to the CPU block (+5 V & +12 V DC isolated) and to the Facia block (+12 V DC).

##### ■ The Facia Block

The Facia Block is accessible from front & constitutes of front black window frame, small size 'S' window reflector capsule or big size 'B' window reflector capsule, Acrylic, Diffuser & Window legend. In case of small window facia there is separator in between two windows. Window legend (Inscription label) is sandwiched between acrylic lens and diffuser plate. Windows can be interchange individually. This facia block can be incorporated with push button capsule. It consist 4 nos. feather push buttons which is fitted in one 'B' size window location OR there is facility of tact keys, which is fitted in name plate frame, depending on no. of window configuration.

## 2.05 Standard Operating Sequence

The MBAS 0600 annunciation systems are programmed to operate as per following operating sequences conforming to ISA standards. Other sequences / non standard sequences are given as per customer's requirement.

Minilec Sequence Code	Operating Sequence Title	ISA Std. Code
S1	Manual Reset	M1
S2	Auto Reset	A1
S3	Ringback	R1-12
S4	First UP	F2M-1

### SEQUENCE S1 : Manual Reset (M1)

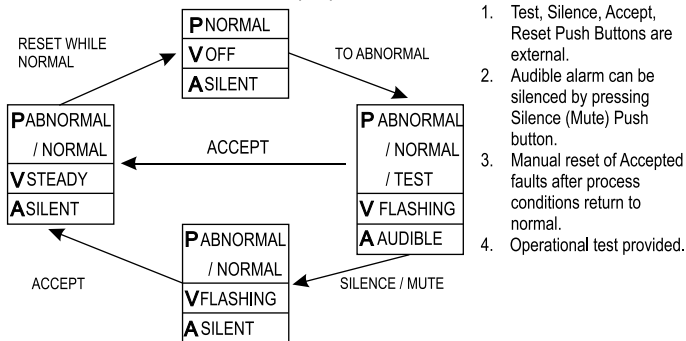

### SEQUENCE S2 : Auto Reset (A1)

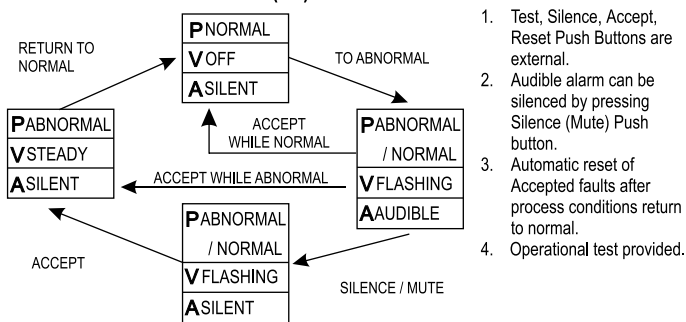

### SEQUENCE S3 : Ringback (R1-12)

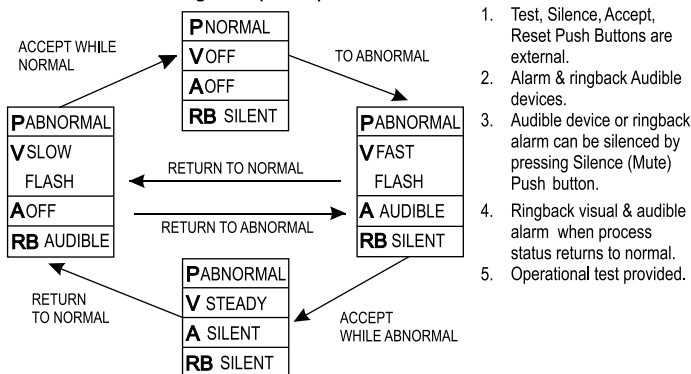

### SEQUENCE S4 : First Out Manual Reset (F2M-1)

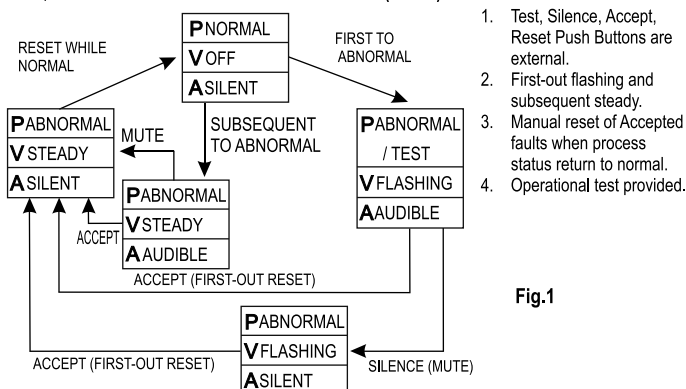

Fig.1

Note:  
P : Process Status, V : Visual Alarm Status, A : Audible Alarm Status, RB : Ringback audible alarm status.

## 2.06 System Enclosures

The MBAS 0600 annunciation systems is configured in multiples of four basic ABS moulded enclosures.



Fig.2 Basic Standard Enclosures

The Facia section, the 'C' cover side plates and the chassis form the enclosure assembly.

1. The 1D size confirms to DIN standard bezel (72 x 144 mm) and panel cutout (68 x 138 mm).
2. The 2D size confirms to DIN standard bezel (144 x 144 mm) and panel cutout (138 x 138 mm).
3. The 3D size confirms to DIN standard bezel (216 x 144 mm) and panel cutout (210 x 138 mm).
4. The 4D size confirms to DIN standard bezel (288 x 144 mm) and panel cutout (282 x 138 mm).

Individual Facia modules (D size) for multipoint alarm systems also conform to DIN standard bezel (72 x 144 mm) and panel cutout (68 x 138).

The terminal block and the DIP Micro Switches are located at the rear of **MBAS 0600**.

## 2.07 Scope of supply

Minilec offers to supply its micro controller based Annunciation system MBAS 0600 as an isolated system to be installed in a suitable control cubicle.

### Minilec's scope of supply is limited to following:

1. MBAS 0600 Standard annunciator module.
2. Built in Power supply block as per Purchase Order specifications. (either AC or DC)
3. Push Button capsules as built-in or external.
4. As per 'B' or 'S' size window order, LED's are mounted on single common PCB in 1D or 2D or 3D or 4D Facia Units as per the ordered configuration. (The window size configuration is coded in the model code number.)

### Following mandatory accessories are also supplied with MBAS 0600

1. 2 Nos. mounting clamps for every 1D, 2D & 3D Box.
2. 4 Nos. mounting clamps for 4D box.
3. User's manual (may be supplied with consignment or will be sent to the user/buyer separately.)

## 2.08 Optional Accessories

Following optional accessories will be supplied only if these are ordered by buyer as additional facilities:

1. Industrial diaphragm type AC or DC Powered Hooter (Audible Device).
2. Electronic (Tone controlled) type AC or DC Powered Hooter (Audible Device).
3. External NO type Push Buttons (4 Nos. = 1 set).
4. Field Contact follower outputs or Ext. repeat relay cards with prefab connection cables. (Min. cable length = 3 mtr).
5. Ringback sequence with 3rd relay output for Ringback hooter.
6. Noise suppressing NETWORK (RRC N/W) supplied with the annunciators to be wired across the inductive load of the audible device. (If ordered)
7. Supply fail Indication / annunciator
8. Supervisory relay contact
9. RS485 with MODBUS communication
10. Maned / Unmanned feature

## 2.09 List of Spares (Recommended)

1. Pre-programmed Microcontroller chip.
2. CPU Card.
3. Power Supply Card.
4. LED Board (Single common PCB).
5. 'S' size window acrylic & diffuser.
6. 'B' size window acrylic & diffuser.
7. Push Buttons Capsule.
8. Repeat Relay Cards.
9. Repeat Relay Card interconnection prefabricated connection cable assembly.

## 2.10 Technical Specifications

1. Supply Voltage 90-270 V AC/DC  
24V/30 V/48 V DC +10%,-15%
2. Supply Frequency(for AC) 50 Hz/60 Hz +/-3%
3. Windows 1D 8 Small (Max) or 4 Big (Max)  
2D 16 Small (Max) or 8 Big (Max)  
3D 12 Big (Max) or 24 small (Max)  
4D 16 Big (Max) or 32 small (Max)
4. Display (Window) Window Acrylic replaceable  
Legends replaceable
5. Window Dimensions  
Small 'S' 31.5 x 30.2mm  
Big'B' 66.2 x 30.2mm
6. Unit Dimensions

	Overall	Cutout
1D	144 x 72 x 215 mm	138 x 68 mm +1/-0mm
2D	144 x 144 x 215 mm	138 x 138 mm +1/-0mm
3D	144 x 216 x 215 mm	138 x 210 mm +1/-0mm
4D	144 x 288 x 215 mm	138 x 282 mm +1/-0mm

7. Weight 1D 800gm.  
2D 1000gm  
3D 1400gm  
4D 1600gm
8. Power Consumption 0.5Watt / window
9. Flash Rate 50-60 Flash / Min. in fast flash  
20-30 Flash / Min. in slow flash
10. Legends Legend plate with inscriptions
11. Operating Sequence S1, S2, S3, S4 (Fixed or Site Selectable)
12. Optional features Any other operating sequence  
Supply fail indication  
Supply fail annunciation  
Repeat Relay Cards  
Supervisory relay contact  
Maned / Unmaned  
RS485 with MODBUS communication  
In built Buzzer or Relay contact site selectable
13. Input Signal Potential free contact  
NO type or NC type as per selection / factory set
14. Input Interrogation Voltage +12 V DC
15. LED Colour in windows Red, Green, Yellow (Amber), White or combination

16. Output  
Two opto isolated Electro-magnetic relay for hooter are provided.  
Third Relay contact (Optional): 3rd Optional relay can be used as (a) Ringback relay when RLY1 & RLY2 used for grouping (b) Supervisory Relay (C) supply fail annunciation.
17. Output Contact rating 5A, 240 V AC (Resistive)
18. Operating Temperature 0°C to 60°C
19. Storage Temperature -10°C to 70°C
20. Humidity Upto 95% Rh
21. Push Buttons Capsule 4 Nos. membrane type (Optional)
22. Enclosure ABS type moulded enclosure with Terminal Strip of High Engineering Plastic Nylon 6.

## 3.00 Installation Instructions

### 3.01 Check list of supply

Check whether following essential items are delivered with your MBAS 0600 annunciator packing box.

MBAS 0600 annunciator module (1D, 2D, 3D or 4D enclosure) as per order and dispatch documents.

- 2 mounting clamps for each 1D size unit /2 Mounting clamps 3D.
- 2 mounting clamps for each 2D size unit/4 Mounting clamps 4D.
- Noise suppressing Network (RRC N/W) if ordered.
- Window inscription photo, (If required) film.
- Other optional accessories if ordered. (The Hooter, external push-buttons, cover plate etc.)
- Verify ordered specifications like number of windows, number of 'B' & 'S' size windows as coded in the model code are incorporated, Input Supply Voltage etc.

### 3.02 Pre-Installation Checks

- i) List the ordered features like —
  - Normal supply voltage.
  - Window size combinations.
  - Number of windows .
  - Number of coloured windows .
  - Operating Sequence Fixed or site selectable.
  - Number of repeat relays.
  - NO/NC fault selection & Grouping site selectable .
- ii) Connect specified normal power supply voltage to your MBAS 0600 and wait. The 'Self-Surveillance' watch-dog LED will switch 'ON' and start flashing. This indicates your MBAS 0600 logic circuit is operating perfectly as designed.
- iii) Below listed test sequence is with a presumption of 'MANUAL RESET(S1)' operating sequence and NO type fault contacts as inputs, with MBAS 0600 in MANNED mode operation.

If 'Push buttons Capsule' is provided as builtin then-

- a) Press 'TEST' push-button. All windows will flash.
- b) Check the output hooter relay RLY 1 is energized and contact (I1) and (C1) is closed.
- c) Press 'MUTE' Push Button Output hooter relay will be de-energize and contacts (I1) & (C1) will open.
- d) Press 'ACCEPT' Push button. All windows should stop flashing and glow steady.
- e) Press 'RESET' Push button to clear all windows. For testing other operating sequence refer sequence chart. (If push button capsule is not provided built-in, then connect external 'NO' type push buttons to test the functioning of your MBAS 0600 module, as detailed above.)

**NOTE :** If push button capsule is not inbuilt, then give Test, Mute, Accept, Reset signals by external 'NO' type switches / push buttons.

- iv) Now, use a 'Shortlink' to actuate individual fault input and operate, MUTE, ACCEPT & RESET push-buttons sequentially.
- a) If repeat Relays are provided, check whether the repeat relay output contacts at terminals FR & FRC actuate on initiating respective fault inputs.
- b) If ringback sequence is used then on fault actuation hooter contacts of RLY 1 or RLY 2 will energize and (I1 & C1 or I2 & C2 will close). On fault normalization before or after ACCEPT command the Ringback Hooter Relay RLY 3 will energize with slow flashing window. (Refer fig. 16)
- c) If grouping facility is provided (Refer fig. 5)  
 RLY 1 will energize for GROUP 1 faults.  
 RLY 2 will energize for GROUP 2 faults.
- d) For 'MANNED' or 'UNMANNED' mode of operation connect externally Double Pole Single Throw Switch as shown in fig.11 of this user's manual. Remove the shortlinks provided at these terminals of MBAS 0600.
- e) Supply Fail Indication. (Refer fig. 12)
- f) Supply Fail Annunciation. (Refer fig. 13)

**NOTE :** Ring Back Sequence facility and grouping facility provided simultaneously in the same MBAS 0600 module.

- v) Check all the individual MBAS 0600 modules as instructed above. Check for configuration of multiple modules of MBAS 0600 as follows:
  - a) Connect Hooter contacts (I1) & (C1) of all the MBAS 0600 in parallel for driving one common audible hooter for a given combination of basic MBAS 0600 modules. Connect the RRC network across Hooter Coils. This RRC Network is supplied assuming that supply voltage of Annunciator and Hooter is same. If Hooter is of different supply voltage then do not connect RRC Network and please ask for RRC Network suitable for hooter coil voltage supply. (Refer fig. 15)
  - b) Similarly connect Push Button terminals TPB, MPB, APB, RPB & (C) of all MBAS 0600 modules in parallel to connect one common set of NO Push Buttons. (Refer fig. 14)

'ACCEPT' push button can be operated directly to acknowledge the faults and silence the audible alarm.

All above test will ensure that your MBAS 0600 annunciators are delivered perfectly as per ordered specifications.

### 3.03 Installation

Install the MBAS 0600 Annunciator modules in designed panel cutout, inserting from front of panel. Before installation please ensure that in the vicinity of MBAS 0600 there are no equipments / systems generating heat, vibration, noise, RF signals etc.

### 3.04 Mounting

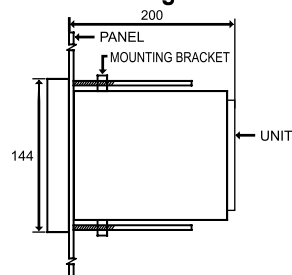

For fixing, use the mounting brackets supplied with the Annunciator, Tighten suitably so that it does not move or get loose.

**Fig 3 Front Panel Mounting**

### 3.05 External Electrical Cable Connections

(Refer Ch.6 of this user's manual)

Connect various fault contact cable (2.5 sq.mm max.) with pin lugs to the fault inputs at terminals with respective labels. Please ensure that these are potential free contacts and do not carry any voltage from source end. Connect Hooter(s) along with RRC Network.

Wherever external repeat relay cards are supplied use prefabricated cables for interconnection between the main annunciator unit & the relay card. Secure male-female connectors tightly. Each repeat card have maximum 16 relays.

### 3.06 Window Legends

For inserting legends or window inscriptions please refer ch.4 of this user manual. Insert the inscribed label at the back of the opaque diffusing plate fitted to the window acrylic lens. The inscription label is sandwiched between the acrylic lens and diffusing plate.

### 3.07 Trip & Non-Trip Group Selection

DIP micro switches (1 to 32 max.) are located at the rear side of MBAS 0600. Select the grouping of window by setting the respective microswitch to ON or OFF position. This facility is provided as site selectable if NO or NC fault configuration is pre-programmed (factory set) or vice versa. (Refer fig. 5)

### 3.08 Sequence Selection

DIP micro switches (No. 1 to 4) are provided at the rear side of MBAS 0600 module. Please select any one sequence at a time by changing the switch position. This facility is given if ordered otherwise fixed sequence is given as per requirement. (Refer fig. 5)

### 3.09 NO/NC Configuration Selection

DIP micro switches (No.1 to 32 max) are located at the rear side of MBAS 0600. Select the switch position to OFF or ON for every individual fault signal as required for NO or NC type fault contact respectively. This facility is provided as site selectable with grouping of faults as pre-programmed (factory set) whenever required. (Refer fig. 5)

### 3.10 Post Installation Checks

Before connecting power supply, please check all wiring terminals for correctness. Please ensure power supply voltage is same as that of MBAS 0600.

### 3.11 Testing & Commissioning

Connect power supply and test for operation of MBAS 0600 as per Testing Flow Chart given in clause 5.02 of ch.5

### 3.12 Precautions

Please ensure that power supply to MBAS 0600 is stable and free from spikes and surges. Please ensure that fault contact cabling does not pick up RF signals. Please ensure that there is no heat generating and vibration near to the MBAS 0600 installation.

## 4.00 Maintenance Instructions

### Instructions for removing and fitting of the front Acrylic for changing the Legends of MBAS 0600.

In case of changing the Legends, release top black locking knob of front black window frame by pulling up top black cover with the help of screwdriver. Hold the front black window frame at bottom and pull out gently.

Hold the black window frame keeping Acrylic plate side at bottom and window reflector capsule side on the top. Pull up the window reflector capsule. In case of small window facia, pull out window reflector capsule without touching separator between two windows. Keep both the thumbs at center of the diffuser plate from back side and press downward. Then front Acrylic plate also will come out with Legend.

#### For refitting

1. Insert the window reflector capsule in the respective slot from top and press it.
2. Locate the cutout slot provided on the front side of the front window frame for holding diffuser plate. Insert the diffuser plate in a slot, keeping plain surface on the front and surface provided with cutout edges on the back side.
3. Put the Legend on top plain surface of the diffuser plate.
4. Insert front Acrylic plate keeping textured finished side on the front and plain surface on back side having cutout edges with small additional locking edges on each side of the plate. Match the cutout edges and press it from all side. The plate gets refitted with locking sound.

5. Always ensure proper insertion and refitting of Acrylic plate.

After fitting of diffuser plate, Legends, Acrylic plate and window reflector capsule, insert the front black window frame in the slot provided in the annunciator front bezel, match the locking knob and push button position at bottom of the front black window frame. Then slightly uphold the top black cover by screwdriver and push the front black window frame inside, so that front black window frame gets locked from top and bottom.

Also, for easiness the steps are shown in sketches below.

Fig.4

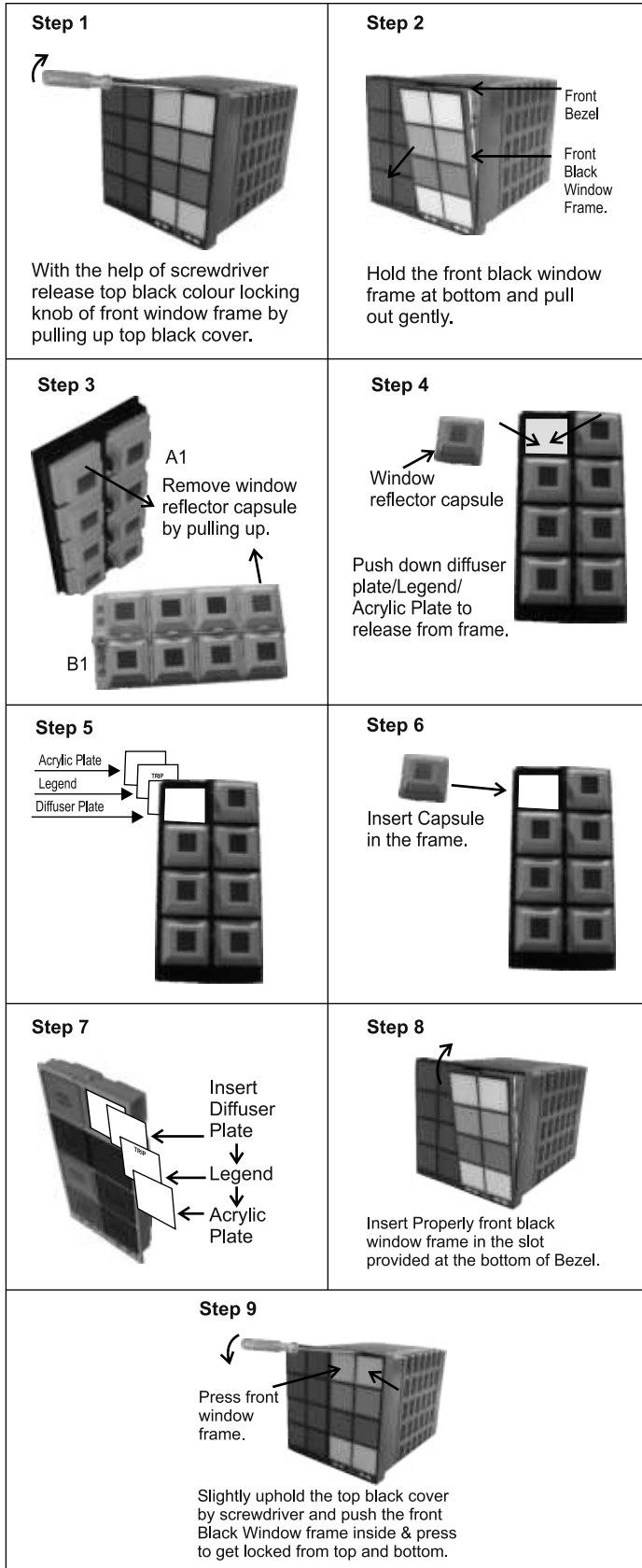

## 5.00 Drawings / illustrations

### 5.01 DIP Switch Settings

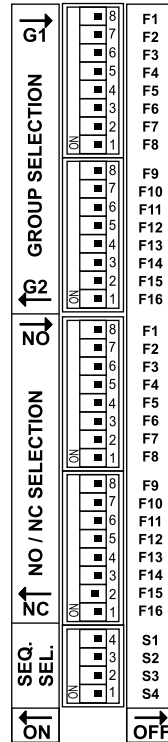

#### SEQUENCE SELECTION :-

To select any one sequence from S1,S2,S3,S4 keep corresponding switch in 'ON' position.

S1 ON	Manual Reset
S2 ON	Auto Reset
S3 ON	Ring Back
S4 ON	First Up

#### NO-NC SELECTION :-

To select type of fault contacts for particular Fault Input. Put corresponding fault switch in 'NO-NC Selection' switch at NO or NC position.

**GROUP SELECTION :-** To select group 1 & group 2 for particular Fault Input. Put corresponding Fault switch (F1 through F16) in 'G1' or 'G2' position.

**Note:** Diagram shows max. 16 Faults. For 24 Faults there will be addition of DIP switches

Fig.5 : DIP Switch Settings

### 5.02 Testing flow chart

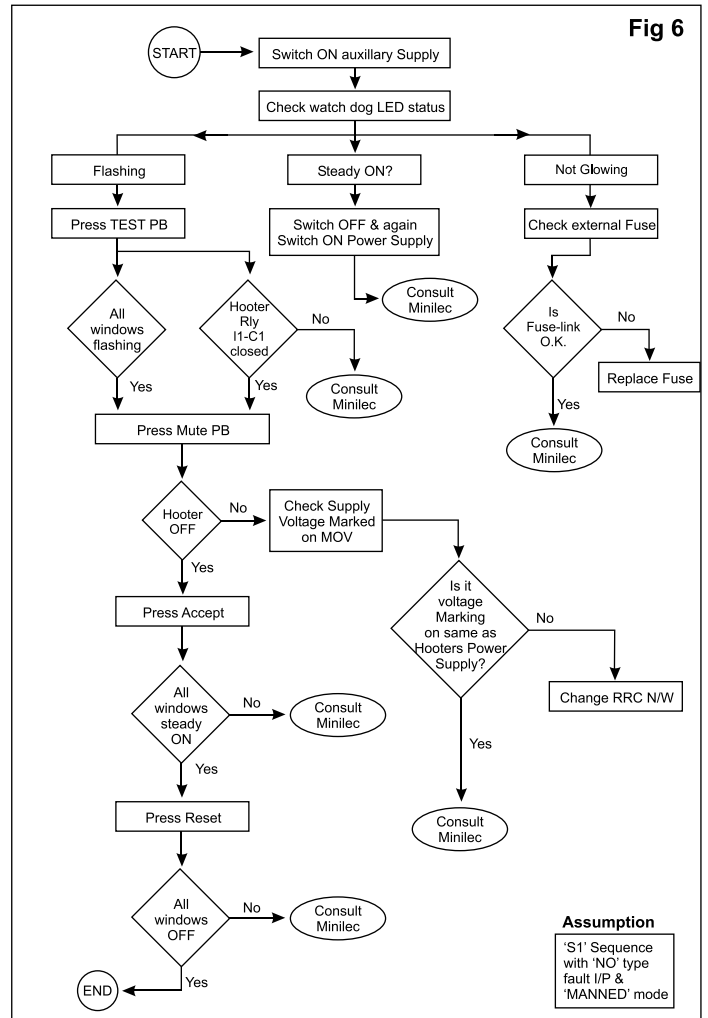

**Assumption**  
'S1' Sequence with 'NO' type fault I/P & 'MANNED' mode

### 5.03 Functional Block Diagram

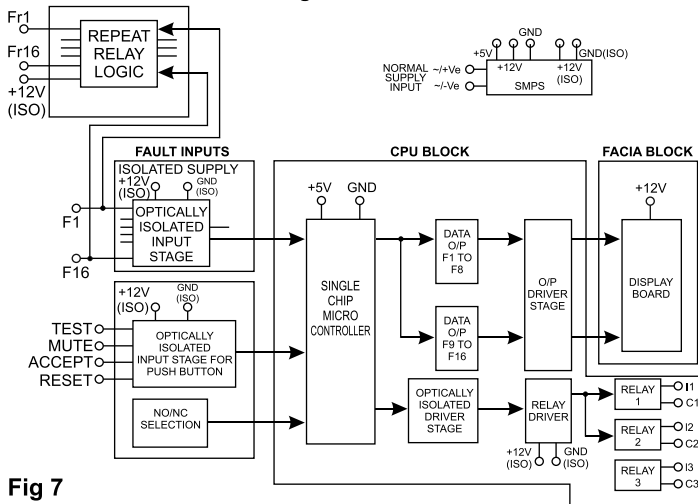
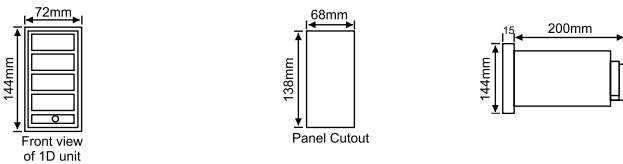
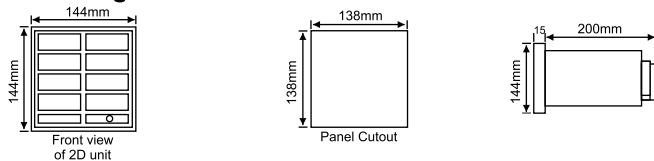

Fig 7

### 5.04 Dimensional & Panel Cutout Details Drawing of 1D Model



### Drawing of 2D Model



### Drawing of 3D Model

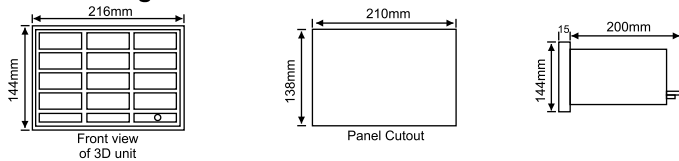

### Drawing of 4D Model

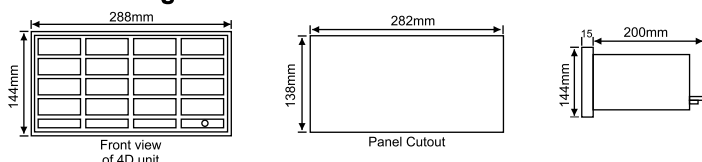

### Mounting & overall Dimensions of External Repeat Relay Card (8/16 Relays)

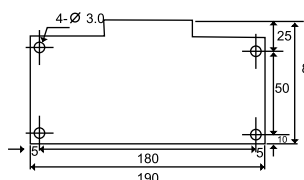

### Mounting & overall Dimensions of External Repeat Relay Card with base (8/16 Relays)

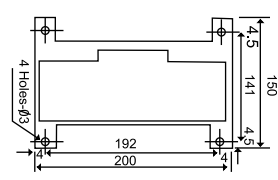

### Acrylic of Repeat Relay Card :

Acrylic & screws of Repeat Relay Card are packed separately with this Repeat Relay Card. Please place acrylic on Repeat Relay Card Spacers & tight with these supplied screws.

### 5.05 3D View of various models with different window sizes with/without push buttons block

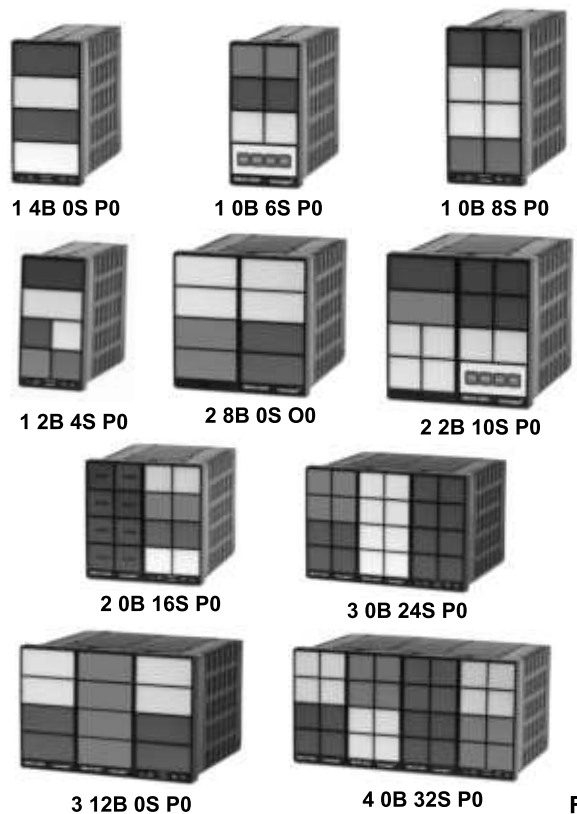
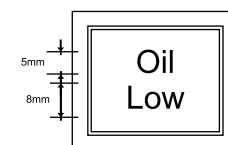
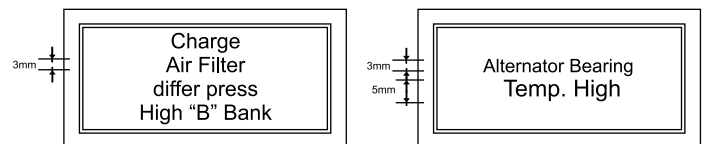

Fig 8

### 5.06 Legends Letter Sizes

MBAS 0600 facia incorporates legend plates which are individually accessible from the front of the unit. General guidelines for selection of letter sizes & number of lines per window are

LETTER SIZE IN mm	NO. OF LINE PER WINDOW	NO. OF LETTERS PER LINE	
		Small windows	Big windows
3	4	9	19
5	3	5	11
8	2	3	5
10	2	3	7



### 5.07 Window Numbering System

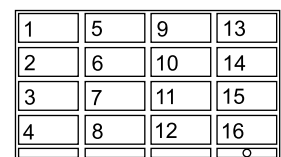
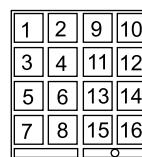

A) 16pt. Small Window configuration

B) 16pt. Big Window configuration

The numbering system is shown for 16pt. models (small & big) for reference. All other models can be referred from this fig.

## 6.00 Connection Diagram

### 6.01 Fault Inputs Connection Diagram

Fig.9

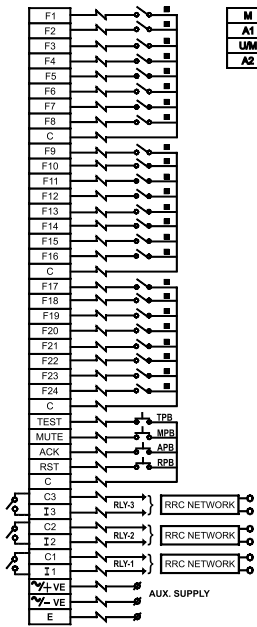

External Terminal connection diagram for Max. 24 point MBAS 0600.

#### NOTES -

- 1) ■ - External potential free fault contacts.
- 2) F - Fault Input contact.
- 3) C - Common Point Fault Input contact.
- 4) TPB- Test Push Button.
- 5) MPB- Mute Push Button.
- 6) APB- Acknowledge Push Button.
- 7) RPB- Reset Push Button.
- 8) RLY-1- Normal Hooter Contact / Group - 1 Hooter Contact.
- 9) RLY-2- Normal Hooter Contact / Group - 2 Hooter Contact / Ring back Hooter contact.
- 10) RLY-3- Optional Relay.  
A) Ring Back Hooter Relay with grouping facility or  
B) Supervisory Relay or  
C) Any other function (Optional).
- 11) Connect RRC network across hooter coil if ordered.
- 12) This is diagram for maximum fault inputs Fn, n=24.

**Note :** Diagram shows maximum 24 faults, for 32 faults, there will be addition of fault inputs.

### 6.02 Stand by Power Source Connection

Fig.10

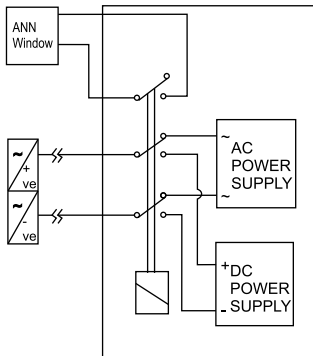

Changeover relay assembly effecting switch over to standby Power Source is external to the annunciator.

Normal supply Voltage	Standby Supply Voltage
90-270 V AC/DC	220 V DC/110V DC
24 V DC	230 V AC/110 V AC, 50 Hz.
48 V DC	24 V AC, 50 Hz.
	48 V AC, 50 Hz.

### 6.03 Manned Or Unmanned Mode

Fig.11

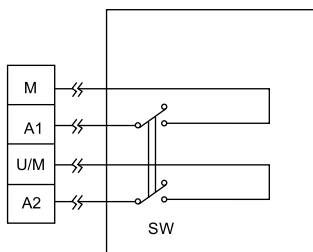

Connect external (shown in the Box) double pole single throw switch (DPST) to enable you to select the MBAS 0600 annunciator in either MANNED mode or UNMANNED mode of operation.

SW SWITCH POSITION	CLOSED	OPEN
MODE OF POSITION	MANNED MODE	UNMANNED MODE

### 6.04 Power Supply Fail Monitoring

Fig. 12

External connection Diagram for Supply Fail Indication Function.

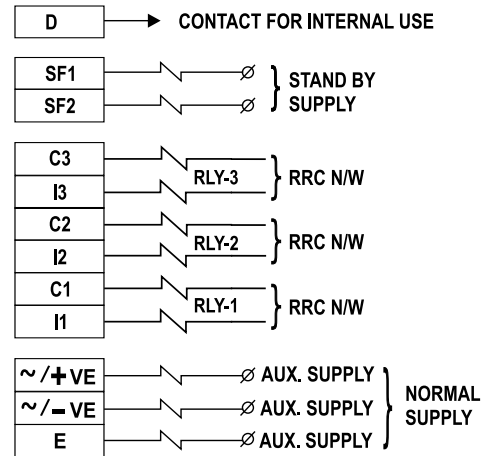

#### NOTES -

- 1) 'D' contact is for internal use only. Do not connect anything to it.
- 2) SF1 - stand by supply connection terminal.
- 3) SF2 - stand by supply connection terminal.
- 4) Connect external connections as per terminal provided on unit.
- 5) Rly-1 and Rly-2 are provided.
- 6) Rly-3 (if applicable).
- 7) Connect supplied RRC network across hooter coil if it is ordered. Hooter supply is same as aux. Supply of annunciator.
- 8) RRC N/W - RRC network.

### 6.05 External connection diagram for supply fail

Fig. 13

annunciation function [Applicable for:- a) Any type of same normal voltage & standby voltage OR b) Different normal voltage & standby voltage within the range of 90V to 270V AC/DC]

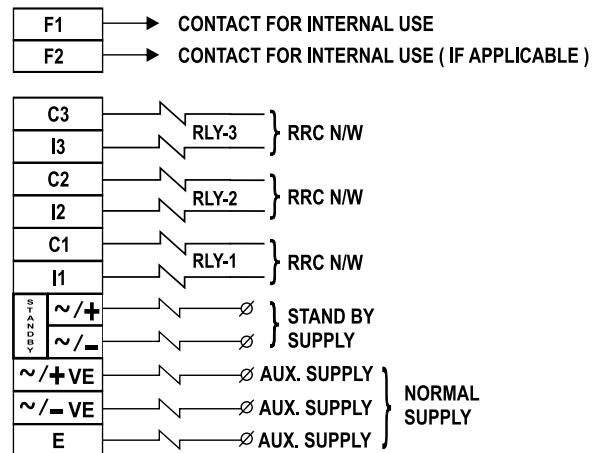

#### NOTES -

- 1) F1 contact is for internal use only. Do not connect anything to it.  
i.e. It is for normal supply fail indication.
- 2) F2 - stand by supply fail indication, it is for internal use only (if applicable).
- 3) Connect external connections as per terminal provided on unit.
- 4) Rly-1 and Rly-2 are provided.
- 5) Rly-3 will operate only when normal supply is absent.
- 6) Connect supplied network across hooter coil if it is ordered. Hooter supply is same as aux. Supply of annunciator.
- 7) RRC N/W - RRC network.
- 8) Keep dip switch F1 of NO / NC selection at NC position.
- 9) Keep dip switch F2 of NO / NC selection at NC position (if applicable).

## 6.06 Push Buttons

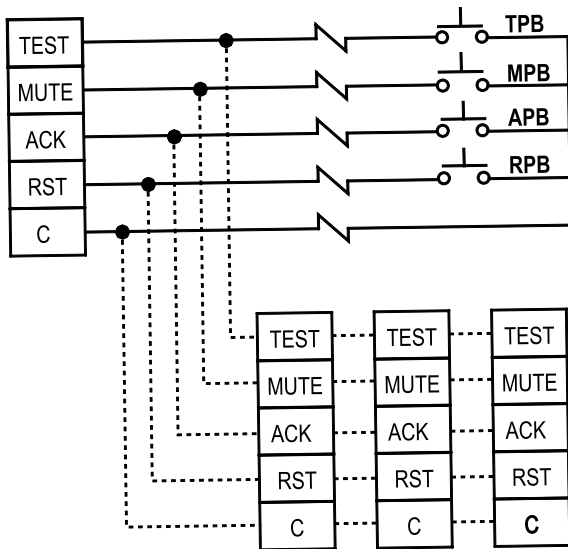
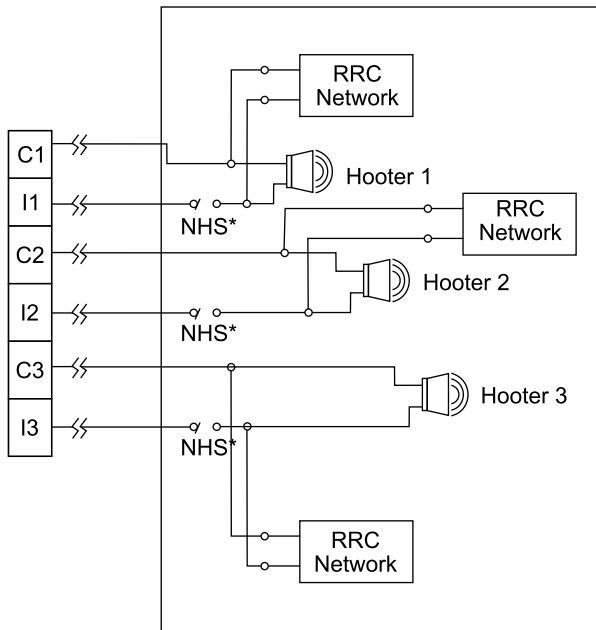

Fig. 14 Common External Push Button Connection diagram

### NOTE:

External Potential NO type Push Buttons. Wherever multiple units (modules) are used together for multipoint windows, the same set of push button should be connected in parallel as shown above.

## 6.07 Hooter Relay Contact Connections, with RRC Network.



\* NHS = Normal Hooter Supply

Fig. 15  
Common Hooter Relay  
connection diagram

- Hooter 1, Hooter 2 & Hooter 3 shown inside the box are external to the annunciator module.
- RLY1 & RLY2 are universally provided with every MBAS 0600 annunciator module. RLY3 is optionally provided on request during the following requirements:
  - a) When Ring Back alarm sequence is asked for.
  - b) When Trip and Non trip grouping of inputs faults is asked for.
- RRC Network will be supplied only if these are ordered by party. It is designed for normal power supply voltage of Hooter coil (load).
- RRC Network used for noise suppression.
- Presumption
- Normal supply voltage of MBAS 0600 and Hooter coil supply voltage are same.
- When more annunciator modules are used together, for multiple window configuration, consult Minilec while ordering or before delivery to enable correct supply of the network RRC or one common audible device (Hooter).
- Connect RRC Network across the hooter coil, if it is ordered.

## 6.08 Parallel Connections for more than one Annunciation Units.

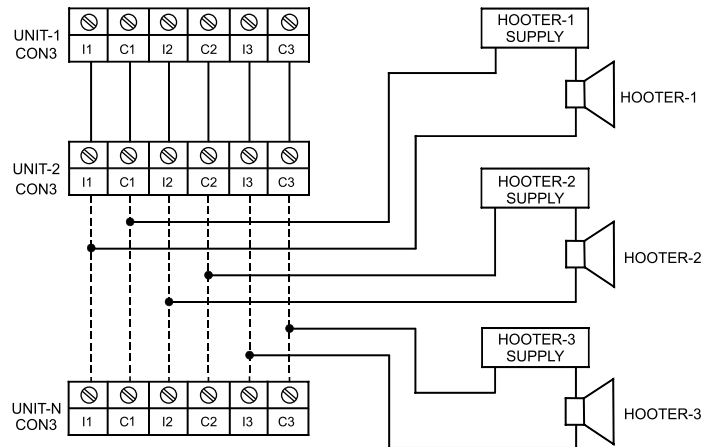

NOTE : UNIT -1, UNIT -2 UPTO UNIT - N ARE CONNECTOR STRIP FOR ANY MBAS 0600.

Fig. 16

## 7.00 COMMUNICATION DETAIL PROTOCOL

- Please use shielded twisted pair cable with characteristic impedance 120Ω to RS485 side.
- The distance up to 1 km.
- Please connect RS485 (+, - & E) of Master device to corresponding RS485 (+, - & E) of annunciator via shielded twisted pair cable

## 7.01 HARD WIRE FAULTS

### SPECIFICATIONS OF SERIAL COMMUNICATION PROTOCOL

ANNUNCIATOR IS ALWAYS A SLAVE DEVICE.

MODE : MODBUS RTU  
 DEVICE ID : Site Selectable as per Device ID Selection Chart.  
 No. OF POINTS : Up to 32 Points.

### Serial Communication Parameters ( Fixed ) :

1. Baud Rate : 9600
2. Data Bits : 8
3. Parity : None
4. Stop Bit : 1
5. Error Check Method : CRC.



■ **Query Format** ( Send by Master Device to Slave Device ) :

Field Name	No. of Characters
Device ID	01
Function Code	01
Starting Address	02
No. of Points	02
CRC	02

■ **Response Format** ( Send by Slave Device to Master Device ) :

Field Name	No. of Characters
Device ID	01
Function Code	01
Byte Count	01
Data *	YY
CRC	02

\* - No. of characters of data for 8 Points / 16 Points / 24 Points / 32 Points is 01 / 02 / 03 / 04 respectively

■ **Exception Response Format** (Send by Slave Device to Master Device ) :

Field Name	No. of Characters
Device ID	01
Function Code	01
Error Number	01
CRC	02

**Example** : 1. To read fault status from Annunciator, having Device ID = 10 ( Device ID should be sent in HEX form, i.e. 0Ah in this case. Device ID can be decided from Device ID selection chart which is given onwards. ), Master has to send the following query :

Field Name	Hex Code
Device ID	0A
Function Code	02
Starting Address Hi	00
Starting Address Lo	00
No. of Point Hi	00
No. of Point Lo *	18
	CRC

\* - Hex code for 8 Points = 08h, 16 Points = 10h, 24 Points = 18h & 32 Points = 20h.

2. In response of above query, Annunciator will send following response code :

Field Name	Hex Code
Device ID	0A
Function Code	02
Byte Count **	03
Data Byte 1 ( Fault Status of Fault 8 to 1 ) **	XX
Data Byte 2 ( Fault Status of Fault 16 to 9 ) **	XX
Data Byte 3 ( Fault Status of Fault 24 to 17 ) **	XX
Data Byte 4 ( Fault Status of Fault 32 to 25 ) **	XX
CRC Lo	
CRC Hi	

\*\* - As per the " No. of Point Lo " : 08h / 10h / 18h / 20h in query, the Byte Count is 01h / 02h / 03h / 04h & Data Byte can be Data Byte 1 / Data Byte 1,2 / Data Byte 1,2 & 3 / Data Byte 1, 2, 3 & 4 respectively.

The significance of the bit in the data bits of the Data Byte 1 for above example is shown below :

Bit 7 Status of Fault 8	Bit 6 Status of Fault 7	Bit 5 Status of Fault 6	Bit 4 Status of Fault 5	Bit 3 Status of Fault 4	Bit 2 Status of Fault 3	Bit 1 Status of Fault 2	Bit 0 Status of Fault 1
-------------------------------	-------------------------------	-------------------------------	-------------------------------	-------------------------------	-------------------------------	-------------------------------	-------------------------------

If Bit 0 of Data Byte 1 = 0, It means Fault 1 is absent.  
If Bit 0 of Data Byte 1 = 1, It means Fault 1 is present.

3. In case of error in query, Slave Device will send following exception response code :

■ **Exception Response Format** :

Parameter	Hex Code
Device ID	0A
Function Code	82
Error Number	ZZ
CRC Lo	
CRC Hi	

**Note** : Function Code = 82h, only in case of Error Number 02 & Error Number 03.

ZZ = Error Number

Error Number 01 : Invalid Function Code.

Error Number 02 : Invalid Data Address.

Error Number 03 : Invalid selection of Point Code.

**7.02 SOFT WIRE FAULTS**

**SPECIFICATIONS OF SERIAL COMMUNICATION PROTOCOL**

**ANNUNCIATOR IS ALWAYS A SLAVE DEVICE.**

**MODE** : MODBUS RTU

**DEVICE ID** : Site Selectable as per Device ID Selection Chart.

**No. OF POINTS** : Up to 32 Points.

**FAULTS INPUT STATUS** : From Master Device to Annunciator through Serial Communication.

**NO / NC** : Not Applicable.

**Serial Communication Parameters ( Fixed ) :**

- Baud Rate : 9600
- Data Bits : 8
- Parity : Even
- Stop Bit : 1
- Error Check Method : CRC.

■ **Query Format** ( Send by Master Device to Slave Device ) :

Field Name	No. of Characters
Device ID	01
Function Code	01
Starting Address	02
No. of Points	02
No. of Bytes	01
Data	04
CRC	02

■ **Response Format** ( Send by Slave Device to Master Device ) :

Field Name	No. of Characters
Device ID	01
Function Code	01
Starting Address	02
No. of Register	02
CRC	02

■ **Exception Response Format** ( Send by Slave Device to Master Device ) :

Field Name	No. of Characters
Device ID	01
Function Code	01
Error Number	01
CRC	02

**Function Details :**

All Faults are sent by Master Device to Annunciator via Serial Communication using MODBUS RTU Protocol. Faults will not be taken from Fault Terminal Inputs.

**Example :**

1. To send Fault status from Fault 1 - Fault 32 to Annunciator, having Device ID = 10 ( Device ID should be sent in HEX form, i.e. 0Ah in this case. Device ID can be decided from Device ID selection chart which is given onwards. ), Master has to send the following query :

Field Name	Hex Code
Device ID	0A
Function Code	10
Starting Address Hi	00
Starting Address Lo	00
No. of Point Hi	00
No. of Point Lo	02
No. of Bytes	04
Data Byte 1 : F8 (MSB) to F1 (LSB)	XX
Data Byte 2 : F16 (MSB) to F9 (LSB)	XX
Data Byte 3 : F24 (MSB) to F17 (LSB)	XX
Data Byte 4 : F32 (MSB) to F25 (LSB)	XX
	CRC

2. In response of above query, Annunciator will send following response code :

Field Name	Hex Code
Device ID	0A
Function Code	10
Starting Address Hi	00
Starting Address Lo	00
No. of Register Hi	00
No. of Register Lo	02
CRC Lo	
CRC Hi	

The significance of the bit in the data bits of the Data Byte 1 for above example is shown below :

Bit 7	Bit 6	Bit 5	Bit 4	Bit 3	Bit 2	Bit 1	Bit 0
Status of Fault 8	Status of Fault 7	Status of Fault 6	Status of Fault 5	Status of Fault 4	Status of Fault 3	Status of Fault 2	Status of Fault 1

If Bit 0 of Data Byte 1 = 0, It means Fault 1 is absent.

If Bit 0 of Data Byte 1 = 1, It means Fault 1 is present.

3. In case of error in query, Slave Device will send following exception response code :

**Exception Response Format :**

Parameter	Hex Code
Device ID	0A
Function Code	90
Error Number	ZZ
CRC Lo	
CRC Hi	

Note :- Function Code = 90h, only in case of Error Number 02 & Error Number 03.

ZZ = Error Number

Error Number 01 : Invalid Function Code.

Error Number 02 : Invalid Data Address.

Error Number 03 : Invalid selection of Point Code.

**7.03 DEVICE ID Selection Chart :**





Sr. No.	P8	P7	P6	P5	P4	DEVICE ID ( Decimal )
1.	0	0	0	0	0	1
2.	0	0	0	0	1	1
3.	0	0	0	1	0	2
4.	0	0	0	1	1	3
5.	0	0	1	0	0	4
6.	0	0	1	0	1	5
7.	0	0	1	1	0	6
8.	0	0	1	1	1	7
9.	0	1	0	0	0	8
10.	0	1	0	0	1	9
11.	0	1	0	1	0	10
12.	0	1	0	1	1	11
13.	0	1	1	0	0	12
14.	0	1	1	0	1	13
15.	0	1	1	1	0	14
16.	0	1	1	1	1	15
17.	1	0	0	0	0	16
18.	1	0	0	0	1	17
19.	1	0	0	1	0	18
20.	1	0	0	1	1	19
21.	1	0	1	0	0	20
22.	1	0	1	0	1	21
23.	1	0	1	1	0	22
24.	1	0	1	1	1	23
25.	1	1	0	0	0	24
26.	1	1	0	0	1	25
27.	1	1	0	1	0	26
28.	1	1	0	1	1	27
29.	1	1	1	0	0	28
30.	1	1	1	0	1	29
31.	1	1	1	1	0	30
32.	1	1	1	1	1	31

1 = " DEVICE ID SELECTION " DIP Switch at ON Position.

0 = " DEVICE ID SELECTION " DIP Switch at OFF Position.

In " DEVICE ID SELECTION " DIP Switch : P1 to P3 are don't care.

**8.00 Inbuilt Buzzer or Relay Contact Selection Chart :**

Inbuilt Buzzer or Relay Contact Selection Chart	
Slide Switch Position	Feature Selected
 RLY1	Relay Contact I1, C1 Selected
 BZ1	Inbuilt Interrupted Buzzer Selected
 RLY2	Relay Contact I2, C2 Selected
 BZ2	Inbuilt Interrupted Buzzer Selected

**minilec**<sup>®</sup>

**Minilec (India) Pvt. Ltd.**

**Factory & Head Office:**

S. No. 1073/1-2-3, At Post Pirangoot,

Pin: 412 111, Tal.: Mulshi,

Dist.: Pune (INDIA)

Tel.: +91-20-22922354-57

Fax: +91-20-22922134

Email: servicing@minilecgroup.com

Visit us at [www.minilecgroup.com](http://www.minilecgroup.com)



**5 Years Warranty**

(For free repairs & servicing from date of supply against manufacturing defects only.)